

1. Key arrangements
2. Menu arrangements
3. Config, settings and modes
4. Operational modes
5. BASE menu
6. x! function in PROB menu
7. ALPHA mode HOME menu
8. Display modes: SIG & UNIT
9. SI Prefixes
10. HOME MENU for LAYOUT 1B : Layout for real label WP43C
11. HOME MENU for LAYOUT 42B : Layout for unmodified DM42
12. ASSIGN & Pre-Packed Profiles (PPP)
13. In progress
14. Text changes
15. ELEC Menu 1
16. ELEC Menu 2
17. Calculator operation notes
18. f and g shift operations
19. Full BLUE key Layout 42B for unmodified DM42
20. INFO menu
21. GRAPH
22. New Functions/modes/settings not in WP43S
23. Simulator Operation
24. WP43C Emulator photographs compared with other calculators
25. Keyboard overlay
26. Resources and references
27. Chronological updates since beginning 2020.

BLACK - No changes (only image updates)

ORANGE- Minor changes

RED - Major changes

THIS DOCUMENT IS A WORK IN PROGRESS

1. Key arrangements

The keyboard differences compared, excluding the various direct math keys in the first 3 rows.

	WP43C LAYOUT 1B (DM42 KEY OVERLAY)	WP43C LAYOUT 42B (UNMODIFIED DM42)	WP43S (DM42 KEY LABELS & KEY OVERLAY)
SIN, COS, TAN	Unshifted keys	Unshifted keys	TRI softmenu
ASIN, ACOS, ATAN	f shifted keys	f shifted keys	TRI softmenu
RMD	INTS softmenu	INTS softmenu	f-shifted key
RND / ROUND	f shifted key	f shifted key	DISP softmenu
SF, CF	FLAGS softmenu	FLAGS softmenu	f and g shifted keys
d.ms	MODE softmenu	MODE softmenu	f shifted key
FILL	STK menu	STK menu	f shifted key
Caps Lock	Alpha mode f shifted key, also up/dn keys	Alpha mode f shifted key, also up/dn keys	Arrow keys alternating between menu change and shift state change
LASTx	f shifted key	f shifted key	Not on key. RCL L.
%	f shifted key	f shifted key	N/A
x!	PROB softmenu	PROB softmenu	f shifted key
Σ+	Direct key	Direct key	STAT softmenu
TRI	Softmenu from HOME	Softmenu from HOME	Direct key
Reconfigurable normal key	Σ+ can be reconfigured	Σ+ can be reconfigured	N/A
USER mode key ASSIGN packs	3 custom packs	3 custom packs	N/A
UNDO	f shifted key	g shifted key	f-shifted key. Not active.
Screen shot	SHIFT + DISP	—	SHIFT + DISP



WP43C Layout 1B



WP43S

2. Menu arrangements

WP43C

A few of the softmenu arrangements were changed from the original WP43S allocations. Some details are shown below:

WP43S

[g] CPX

The CPX menu is a re-arranged but largely retains the same functions as in the WP43S. Menu items were added for CC (original WP43S) & COMPLEX (42S style).

RECT/POLAR swapped around to align with HOME

CPXi	CPXj	CX→RE	RE→CX	RECT	POLAR
COMPLEX	CC	dot	cross	sign	UNITV
Re	Im	x	conj	ReIm	

Complex entry options:
 - **COMPLEX**: HP42S
 - **CC**: WP43S

[g] CPX

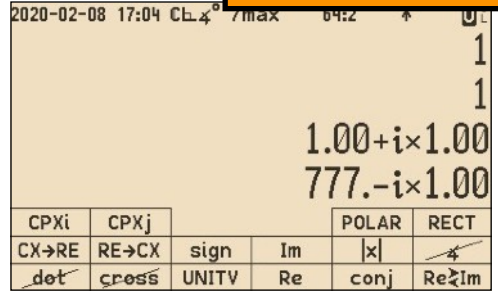

[g] EXP

The EXP menu is re-arranged but largely remains the same as in the WP43S, with the indicated changes.

Re-arranged FN keys to better align with top line keys Σ+, 1/x ...

sinh	cosh	tanh	arsinh	arcosh	artanh
$\sqrt[3]{x}$	$\sqrt{x/y}$	\sqrt{x}	2^x	e^{x-1}	$\ln(1+x)$
x^3	y^x	x^2	lb x	e^x	$\log_x y$

RND ab/c y^x * x² √y 10^x .d e^x .mo GTO LBL

Σ+ A 1/x B √x C LOG D LN E XEQ F

[g] EXP

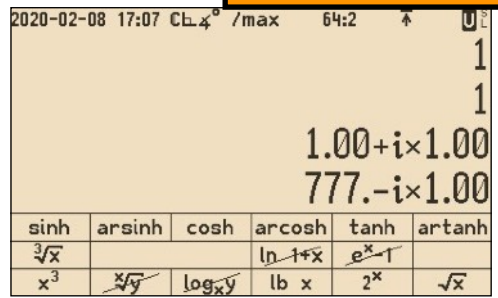

[g] HOME: TRIG

The TRIG menu is not on a keyboard label, as the actual DM42 SIN/COS/TAN keys are available.

TRIG and EXP menu re-arranged to follow the SIN/COS/TAN sequence of the keys.

 TRIG is available from HOME, with additions to facilitate angle mode change.

sinh	cosh	tanh	arsinh	arcosh	artanh
DEG	RAD	GRAD	d.ms	→R	→P
SIN	COS	TAN	ASIN	ACOS	ATAN

|x| < % Δ% π R↑ ASIN →R ACOS →P ATAN RTN

STO G RCL H R↑ I SIN C COS K TAN L

TRI

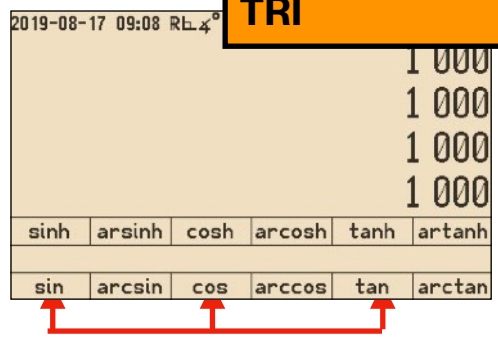

[f] STK

Stack related functions were added to the STK menu for convenience.

FILL added as it was removed from the keys, and R^ added as it was removed from Layout 42B.

FILL	LASTx	R↓	R↑	DROP↓
x↓	y↓	z↓	t↓	z
				CLSTK

[g] STK

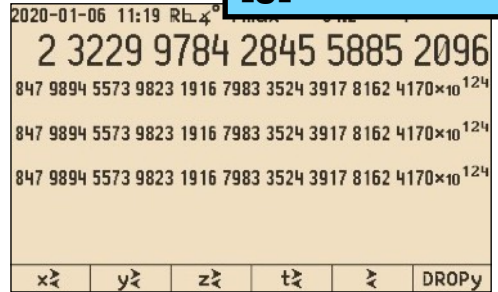

[f] CONV: UNIT

UNIT moved into CONV.

Full text used on unit categories, not single letter abbreviations.

°C→°F	°F→°C	Volume:	Area:
Energy:	Power:	F&p:	Mass:
			Dist:

[g] U>

°C→°F	°F→°C	s→year	V:	A:
E:	P:	year→s	F&p:	m:
				x:

3. Config, settings and modes

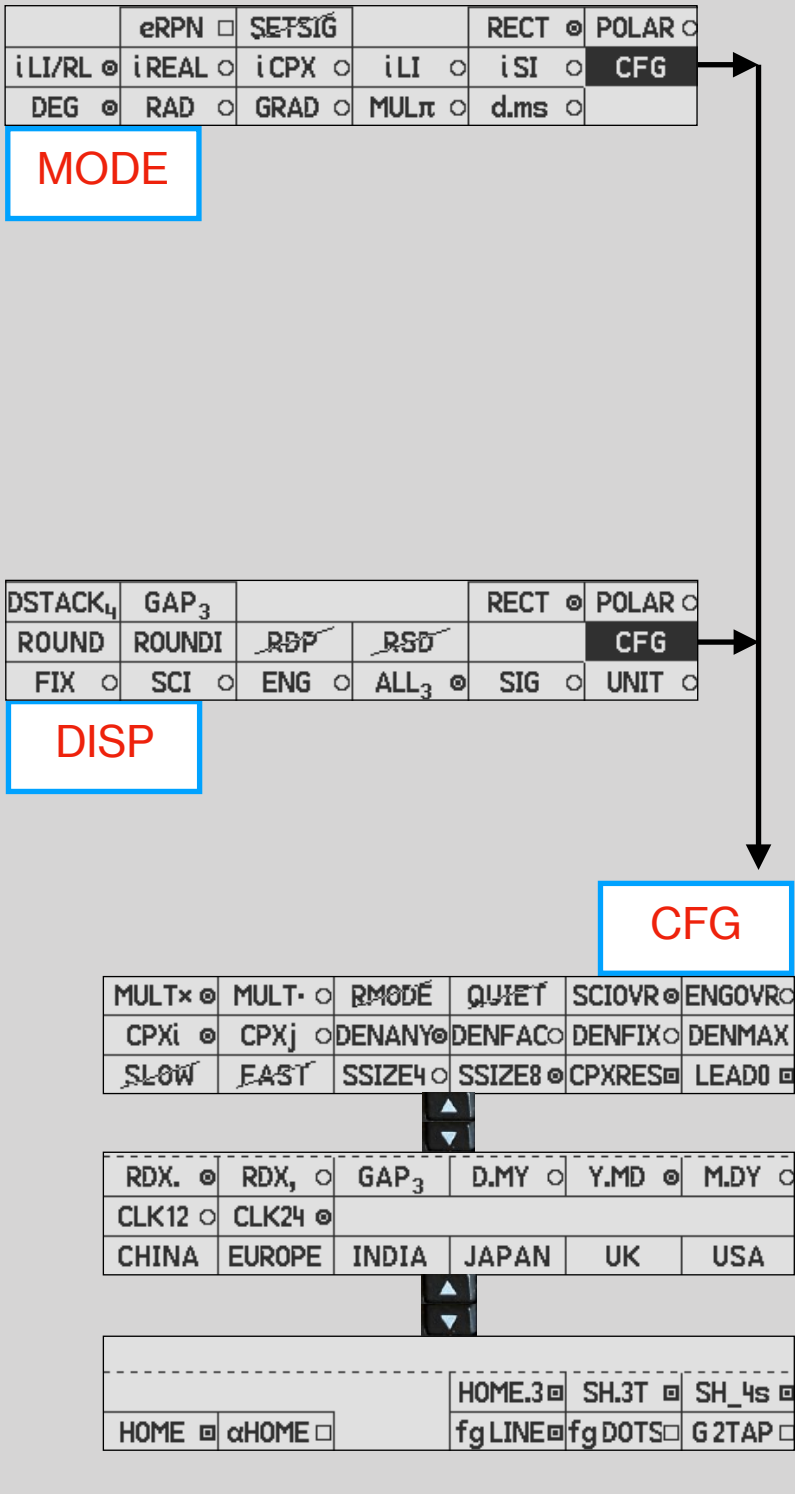

Input modes: Default behaviour of the WP43S is Longint, unless a decimal point (or EEX) is typed indicating REAL, or a # is typed for Shortint. The input modes was added to WP43C to change the default input type:

- i LI/RL Longint / Real as per WP43S **.
- i REAL REAL
- i CPX Complex
- i LI Longint
- I SI Shortint

- RECT/POLAR Notation **
- eRPN Prevents ENTER to copy X->Y
- SETSIG Precision setting **
- DEG/RAD/GRAD/MUL π /d.ms ADM **

- GAP Decimal digit spacing **
- DSTACK Displayed stack levels **
- ROUND, ROUNDI, RDP, RSD Rounding **
- FIX, SCI, ENG, ALL Display Format **
- SIG Displays significant digits and zeroes insignificant digits.
- UNIT Uses ENG format, but replaces 10ⁿ with SI prefixes k, M, etc.

** As per the WP43S OM and ReM.

CFG screen 1
Re-arranged, but as per the WP43S OM and ReM.

CFG screen 2
Re-arranged, but as per the WP43S OM and ReM.

- CFG screen 3**
WP43C specific settings
- HOME makes HOME the base screen
 - α HOME makes the ALPHA menu the base screen during alpha entry
 - HOME.3 Activates triple press HOME
 - SH.3T Modifies the triple shift timer
 - SH_4s Activates the 4 second shift cancel
 - FG LINE Activates underlining of the active softmenu cell
 - FD DOTS Activates the dot indication of shifts
 - G 2TAP Activates double tap FN keys to select g[FN]

WP43C

4. Operational modes

[f] MODE

HOME base menu settings

HOME.3 & SH.3T switch keyboard control

4 Second f & g shift cancelling.

eRPN switch

Input mode setting

HOME	αHOME	HOME.3	SH.3T	SH_4s
FG LINE	FG DOTS	G 2TAP		

CFG3

eRPN	SETSIG	RECT	POLAR
i LI/RL	i REAL	i CPX	i LI
i SI	CFG	DEG	RAD
GRAD	MULπ	d.ms	

MODE

HOME base menu settings: Select base menu to be either MYMENU or HOME, individually selectable, to control the base HOME screen. The options are not fully implemented as yet and depends on the WP43S.

HOME.3 & SH.3T switch keyboard control: When selected, a triple shift brings up the HOME menu. Another triple shift removes it. EXIT also removes it.

4 Second f/g shift cancelling: Activates f, g, HOME shift status cancels after 4 seconds.

eRPN switch: When selected, ENTER does not duplicate X -> Y

Input mode setting: This setting forces the default input mode only. All other automation of the WP43S is still applicable. Easiest to test this is to use the CLSTK command which is conveniently placed for this use.

- i LI/RL Default mode long integer, with automatic (WP43S) change to real & short integer types
- i REAL Double precision real type
- i CPX Double precision real complex type
- i LI Long integer type
- i SI Short integer type

5. BASE menu

BASE menu added.
Layout 42B keyboard, [f] [4]
Layout 1B keyboard, [f] [1]

The BASE menu was added to have easily available commonly used word sizes as well commonly used number base

(HOME menu):[f] BASE

Shortcuts:
WSIZE shortcuts
Number base shortcuts

LEAD0	WSIZE ₆₄	64-BIT	32-BIT	16-BIT	8-BIT
→LI↔SI	##→INT	→HEX	→DEC	→OCT	→BIN
A	B	C	D	E	F

BASE Menu

- 64-, 32-, 16-, 8-BIT WSIZE shortcuts
- HEX/DEC/OCT/BIN BASE shortcuts
- LEAD0 Leading zeroes **
- WSIZE Word size **
- >LI<>SI Convet Longint to Shortint
- ##>INT As WP43S #
- A..F Hex digits

** As per the WP43S OM and ReM.

6. x! function in PROB menu

Factorial is not on the keyboard as is on the WP43S, hence this function had to find its way to the softmenus, and the **PROB**ability menu seemed to be apt.

WP43C

[f] PROB

WP43S

[g] PROB

Added x! here after being removed from the keyboard due to lack of space.

	NBin:	Geom:	Hyper:	Binom:	Poiss:
LgNrm:	Cauch:	x!	Expon:	Logis:	Weibl:
Norml:	t:	Cyx	Pyx	F:	χ^2 :

	NBin:	Geom:	Hyper:	Binom:	Poiss:
LgNrm:	Cauch:		Expon:	Logis:	Weibl:
Norml:	t:	Cyx	Pyx	F:	χ^2 :

7. ALPHA mode HOME menu

The base changes on the ALPHA mode keyboard were to keep the letters in the same sequence as the DM42 key layout. This change caused the menu keys to disappear, hence a softmenu had to be developed.

Moved all the alpha mode commands/menus into a ALPHA HOME menu due to congestion on the re-

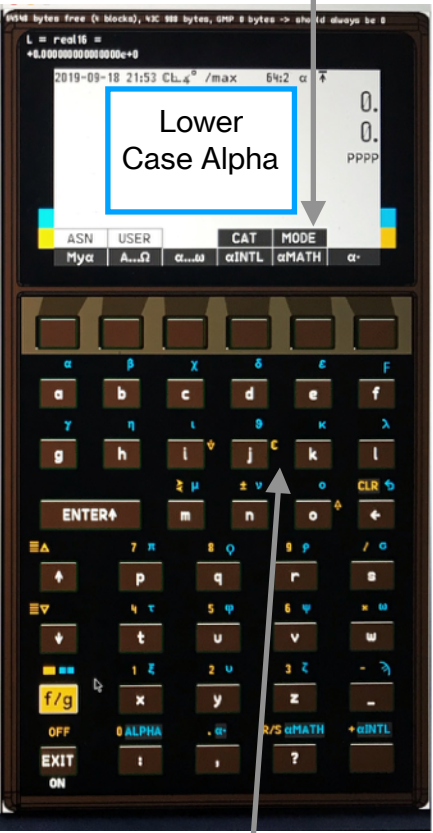
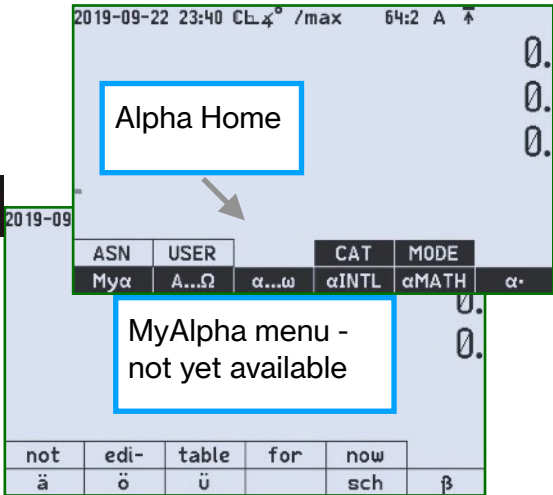

Re-arranged the alpha keys follows the HP42S / DM42 sequence

Alpha HOME

Shortcuts

Caps Lock

10. HOME MENU for LAYOUT 1B : Layout for real label WP43C

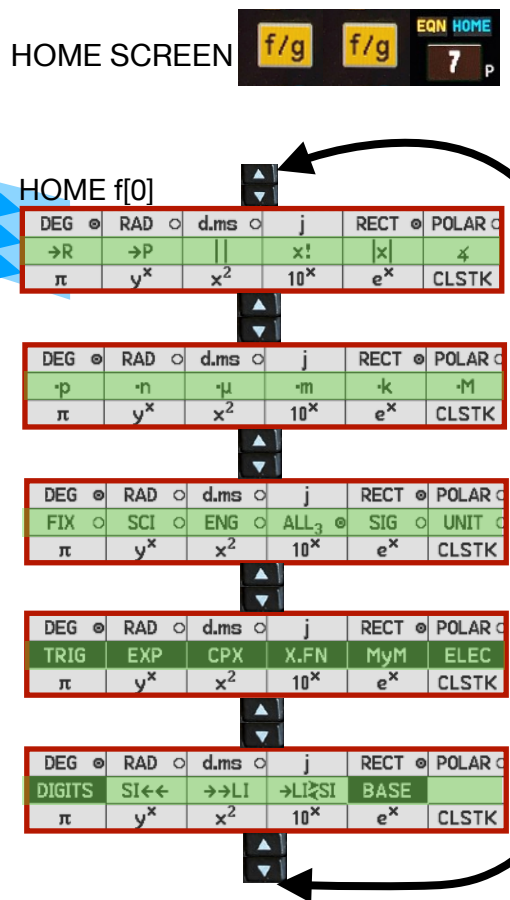

Notes:

- HOME screen gets activated by f/g f/g f/g or f/g f/g 7.
- Same sequence, or EXIT to remove the HOME screen.
- General modes. 4 screens with various useful menus items from various different menus screens combined.
- ↓ ↑ wrap around to the top screen, in both directions.

11. HOME MENU for LAYOUT 42B : for unmodified DM42

HOME MENU LEGEND FOR UNMODIFIED DM42



Unmodified DM42, no blue labels, showing original yellow labels.

(OFFIMG is a close up picture of the Nefertiti bust in Charlottenburg, Berlin).

Notes:

1. HOME screen gets activated by **f/g** **f/g** **f/g** or **f/g** **0**
2. Same sequence, or **EXIT** to remove the HOME screen.
3. Blue labels: Press **↓** to get 3 legend screens showing the blue labels, as the arrows indicate. The menu shows in the actual layout on the keyboard, so a sequence can be seen and remembered. The 3 screens are in a way active help to show where the blue commands are.
4. General modes. The same 4 general screens with various useful menus and items from various different menus screens combined. See Layout 1B for details.
5. **↓** **↑** wrap around to the top screen, in both directions.

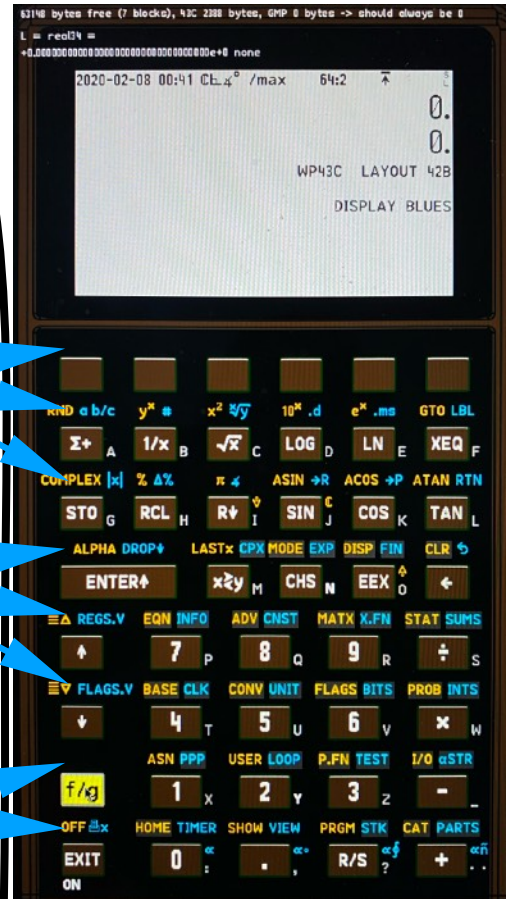
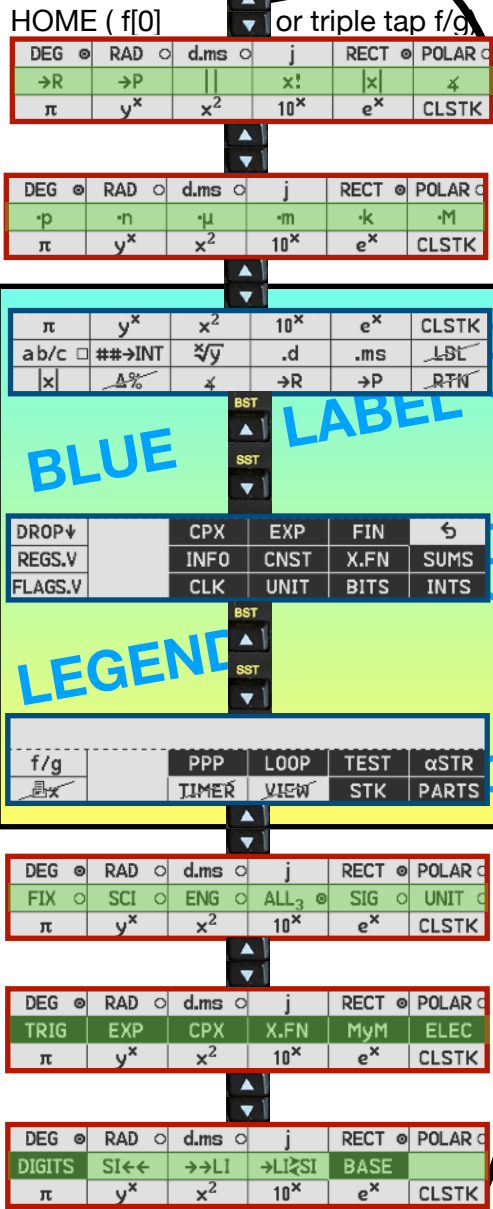

Simulator showing hidden blue labels on unmodified DM42

12. ASSIGN & Pre-Packed Profiles (PPP)

ASN or ASSIGN is not yet implemented by 43S. This promises to be a major feature, and I would like to use the 43S engine for that. In the mean time, we added an assign function in order to provide packages groups of keyboard layout.

Pre-packed Profiles or PPP are combinations of preset groups of assigned keys, to do a quick reconfiguration of multiple keys.

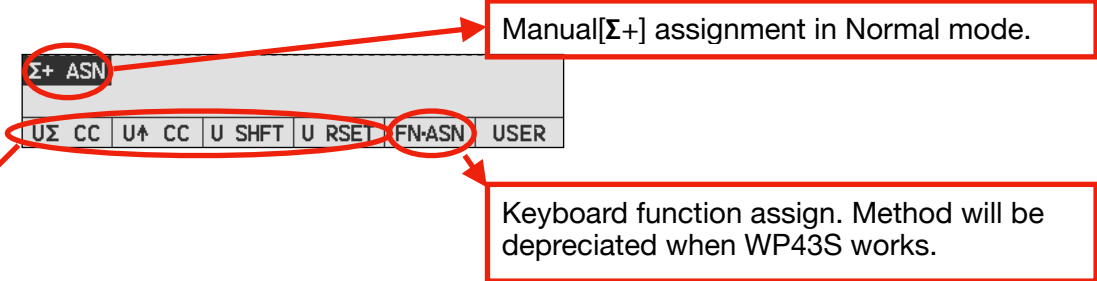

PPP has three USER MODE packages and a RESET at this point:

UΣ CC	[Σ+] f[Σ+] g[Σ+]	CC as per WP43S OM SI<< : X: To dec [.d]; and from dec to ShortInt >>LI : X: To dec [.d]; and from dec to Longint	
U↑ CC	[Σ+] f[Σ+] g[Σ+] g[ENTER]	MyMenu as per WP43S OM SI<< : X: To dec [.d]; and from dec to ShortInt >>LI : X: To dec [.d]; and from dec to Longint CC as per WP34S OM	
U SHFT	[Σ+] SIN COS TAN f[SIN] g[SIN]	USER as per WP43S OM TRIG menu f-shift g-shift USER RTN NOTE: [Σ+] is USER in both U and normal modes and note K and L does not work in ALPHA.	
		Combined packaged modes: This case was U↑ CC and U SHFT	
U RSET FN-ASN USER		Resets all user mode setting Set a keyboard function to user mode Shortcut to USER on primary function key	

In progress

14. Text changes

The following labels have changed. When using the WP43S documentation, ensure you use the correct text! Needs to be updated

WP43S	WP43C	WP43C location. Comment.
/	Divide	Primary key. Change in simulator only, not on DM42.
sin	SIN	Primary key. As per DM42.
cos	COS	Primary key. As per DM42.
tan	TAN	Primary key. As per DM42.
arcsin	ASIN	Primary key. As per DM42.
arccos	ACOS	Primary key. As per DM42.
arctan	ATAN	Primary key. As per DM42.
α.FN	αSTR	Yellow label: [f] [4]. Switch to alphanumeric mode.
E	EEX	Primary key. Change in simulator only, not on DM42.
In	LN	Primary key. As per DM42.
lg	LOG	Primary key. As per DM42.
R←	→R	Blue label: [g] SIN. Changed arrow direction due to location.
P/R	PRGM	Yellow label: [f] [R/S]
RBR	REGS	Blue label: g[Up]. Register viewer
STATUS	FLAG.V	Blue label: g[Dn]. Global flag viewer
TRI	TRIG	Not on keyboard anymore, only on menu.
U→	UNIT	Blue label: [g] [5]. Unit conversions.
∠→	CONV	Yellow label: [f] [5]. DEG/RAD/... conversions.
+/-	CHS	Primary key. Change in simulator only, not on DM42.
CATALOG	CAT	Yellow label: [f] [+].
CC	COMPLEX	Yellow label on [f] [ENTER]. To compose and decompose complex numbers.
	eRPN	Additional mode setting. Menu item.
	eRPN?	Additional mode setting confirmation. Menu item.
	HOME.3	Additional mode setting. Menu item.
	HOME.3?	Additional mods setting confirmation. Menu item.
	HOME	Additional menu system. Menu.
	UNIT	Additional display mode (k, M, G). Menu item.
	SIG	Additional display mode floating decimal point. Menu item.
	ALPHA	Additional alpha entry mode menu.
	BASE	Additional shortcut menu to change to bases. Menu.
	→BIN	Additional shortcut for conversion to base. Menu item.
	→OCT	Additional shortcut for conversion to base. Menu item.
	→DEC	Additional shortcut for conversion to base. Menu item.
	→HEX	Additional shortcut for conversion to base. Menu item.
	8-BIT	Additional shortcut in BASE to set WS. Menu item.
	16-BIT	Additional shortcut in BASE to set WS. Menu item.
	32-BIT	Additional shortcut in BASE to set WS. Menu item.
	64-BIT	Additional shortcut in BASE to set WS. Menu item.

15. ELEC MENU 1

The ELEC menu is an attempt to evaluate the concept of an application module of programmed complex math (in C), using the 43S routines written for RPN. The ELEC module is based on the standard electrical engineering formulas below:

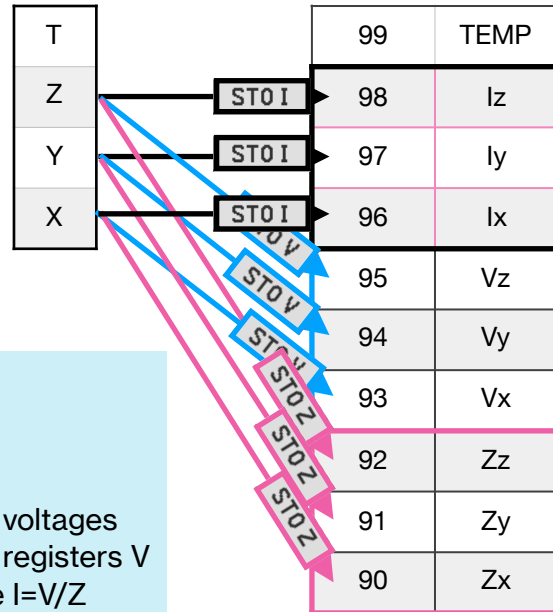

Example calculation: Calculate the line currents from an unbalanced system fed from an unbalanced voltage:

Enter [2,1,3] as the delta connected impedance
 Convert to star equivalent
 Star result

Store into triple memory Z
 Enter star connected voltages
 Store into triple registers V
 Compute I=V/Z

T	
Z	2
Y	1
X	3

0.333
0.5
1

189
203
232

567
406
232

Average: + + 3 / **401.78 A**

STO Z	RCL Z	STO V	RCL V	STO I	RCL I
V÷I	I×Z	V÷Z	X→BAL		CPX
Y→Δ	Δ→Y	→012	→abc	e^θj	CLSTK

$$R_{AB} = \frac{R_A R_B + R_A R_C + R_B R_C}{R_C}$$

$$R_{BC} = \frac{R_A R_B + R_A R_C + R_B R_C}{R_A}$$

$$R_{AC} = \frac{R_A R_B + R_A R_C + R_B R_C}{R_B}$$

$$R_A = \frac{R_{AB} R_{AC}}{R_{AB} + R_{AC} + R_{BC}}$$

$$R_B = \frac{R_{AB} R_{BC}}{R_{AB} + R_{AC} + R_{BC}}$$

$$R_C = \frac{R_{AC} R_{BC}}{R_{AB} + R_{AC} + R_{BC}}$$

$$V_{A0} = V_0 = (V_A + V_B + V_C) / 3$$

$$V_{A1} = V_1 = (V_A + aV_B + a^2V_C) / 3$$

$$V_{A2} = V_2 = (V_A + a^2V_B + aV_C) / 3$$

$$V_A = V_{A0} + V_{A1} + V_{A2}$$

$$V_B = V_{B0} + V_{B1} + V_{B2} = V_{A0} + a^2V_{A1} + aV_{A2}$$

$$V_C = V_{C0} + V_{C1} + V_{C2} = V_{A0} + aV_{A1} + a^2V_{A2}$$

T	
Z	AB
Y	BC
X	CA

Wye (Y) network Delta (Δ) network

A
B
C

0
1
2

A
B
C

<http://www.ece.uidaho.edu/ee/power/ECE525/Lectures/L15/L15.pdf>

16. ELEC MENU 2

STO Z	RCL Z	STO V	RCL V	STO I	RCL I
V÷I	I×Z	V÷Z	X→BAL		CPX
Y→Δ	Δ→Y	→012	→abc	e^θj	CLSTK

Storage into triple registers
 Calculations
 Conversions

Storage into triple registers

STO Z RCL Z impedance matrix , STO Z RCL Z voltage matrix, store/recall current matrix

Calculations

Ohm's law calculations: $Z=V/I$; $V=IZ$; $I=V/Z$
 Create a three phase balanced quantity X, aX, aaX
 Parallel calc : X || Y converted to X.
 All calculations: Real or Complex.

Conversions

Wye (star) to Delta
 Delta to Wye
 Three phase to sequence components
 Sequence components to three phase
 Euler's formula to create a phasor and others

Example:

Find the delta equivalent of components of an impedance measured to be $6\angle 0$, $12\angle -90$, $11\angle -90$.

```
DEG POLAR SIG 3
6 [ENTER]
12 [ENTER] -90 [COMPLEX]
11 [ENTER] -90 [COMPLEX]
[Y>D]
```

```
22.99-i×90.07
24.01-i×89.93
-1 305.-i×525.0
```

DEG ◉	RAD ○	D→R	R→D	RECT ○	POLAR ◉
Y→Δ	Δ→Y	→012	→abc		CPX
π	j	x ²	a	a ²	CLSTK

Angle mode / Angle conversion / Rectangular / Polar
 Conversions / Calculations
 Constants

Angle mode / Angle conversion / Rectangular / Polar

Angle mode settings for most common engineering DEG / RAD
 Angle conversions for most common engineering DEG / RAD
 RECT / POLAR setting

Conversions

Wye (star) to Delta
 Delta to Wye
 Three phase to sequence components
 Sequence components to three phase
 Parallel calc : X || Y converted to X.
 All calculations can be Real or Complex.

Constants:

x²
 pi
 $i = 1\angle 90^\circ$,
 $a = 1\angle 120^\circ$,
 $a^2 = 1\angle 240^\circ$

Example:

Find the sequence components of a voltage measured to be $120\angle 0$, $21\angle 120$, $31\angle 240$.

```
DEG POLAR SIG 3
120 [ENTER]
21 [ENTER] 120 [COMPLEX]
31 [ENTER] 240 [COMPLEX]
[>012]
```

```
2020-02-08 19:53 C@x° /max 64:2
0.000
sym0 = 31.47∠-5.264°
sym1 = 31.47∠5.264°
sym2 = 57.33∠-3.331×10-34°
```

17. Calculator operation notes

1. HOME menu: Use **f/g f/g 7** or **f/g 0** to pop up HOME menu.

f/g f/g 7 is available in Layout 1B

f/g 0 is available in Layout 42B.

DEG <input type="radio"/>	RAD <input type="radio"/>	d.ms <input type="radio"/>	j	RECT <input type="radio"/>	POLAR <input type="radio"/>
→R	→P		x!	x	↵
π	y ^x	x ²	10 ^x	e ^x	CLSTK

2. **f/g f/g f/g** and **f/g** LONGPRESS are shortcuts to the HOME menu.
The same sequence, or **EXIT** pops the HOME screen off to reveal the previous menu.

Currently, there is a 4 second shift clear, i.e. after 4 seconds [f] and [g] will cancel.

3. The extended HOME menu in Layout 42B accesses [g] keys on an unmodified DM42.

4. Auto DROP is included. CLX (backspace) pressed twice in rapid succession () performs DROP. Key repeat must be within 500 ms.

6. eRPN: Entry RPN is a MODE option. eRPN is “no ENTER stack lift”, as it is done in RPL and on the HP20B/30B.

See Richard J Nelson in "HP RPN Evolves",
<http://h20331.www2.hp.com/hpsub/downloads/S07%20HP%20RPN%20Evolves%20V5b.pdf>

f/g MODE EXIT **CHS** **f/g** **f/g** [eRPN] toggles the setting true or false.

7. Radiobuttons and Checkboxes



All options are made with either Radiobuttons or Checkboxes. This is a visual UI tool to visualise selections, similar to the options of the HP42S.

DEG <input type="radio"/>	RAD <input type="radio"/>	d.ms <input type="radio"/>	j	RECT <input type="radio"/>	POLAR <input type="radio"/>
→R	→P		x!	x	↵
π	y ^x	x ²	10 ^x	e ^x	CLSTK

Radiobuttons: One option of the group can be active at a time.

Checkboxes: Multiple options in the group may be simultaneously selected.

8. Shift indicators: [f] and [g] softmenu **dot** and **line** indicators for shift selection:

Dot **f/g f/g** →

<input type="radio"/>	sinh	cosh	tanh	arsinh	arcosh	artanh
DEG <input type="radio"/>	RAD <input type="radio"/>	GRAD <input type="radio"/>	MULπ <input type="radio"/>	RECT <input type="radio"/>	POLAR <input type="radio"/>	
SIN	COS	TAN	ASIN	ACOS	ATAN	

Line **f/g** →

<input type="checkbox"/>	sinh	cosh	tanh	arsinh	arcosh	artanh
DEG <input type="checkbox"/>	RAD <input type="checkbox"/>	GRAD <input type="checkbox"/>	MULπ <input type="checkbox"/>	RECT <input type="checkbox"/>	POLAR <input type="checkbox"/>	
SIN	COS	TAN	ASIN	ACOS	ATAN	



Single FN **Direct access** →

<input type="checkbox"/>	sinh	cosh	tanh	arsinh	arcosh	artanh
DEG <input type="checkbox"/>	RAD <input type="checkbox"/>	GRAD <input type="checkbox"/>	MULπ <input type="checkbox"/>	RECT <input type="checkbox"/>	POLAR <input type="checkbox"/>	
SIN	COS	TAN	ASIN	ACOS	ATAN	

18. f and g shift operations

The single largest user interface change from the WP43S certainly would be the single shift key on the WP43C as per the DM42 key layout as opposed to the separate f and g keys on the WP43S. This necessitated various ideas to achieve this:

1. Single shift key operation. One press brings up the f mode, and another the g mode. These can be tapped in rapid succession, i.e. double tap to reach g from no shift state.

1. Use  to access gold [f] shifts.
2. Use   to access blue [g] shifts.

2. The shift key press can also be a long continuous keypress, which times out after about one second to f mode, then after another timeout, to g mode.

1. Use  LONGPRESS to access gold [f] shifts, blue [g] shifts.

3. For both (1) and (2) there are various on screen indicators to show which softmenu row is applicable.

1. There is a f/g indication on screen, in the top left corner, as per WP43S standard.
2. There are dots on the extreme sides indicating a single or double tap to reach the f and g lines respectively.
3. There are lines underlining the potentially selected shifted function keys, for the f and g shifted cases.

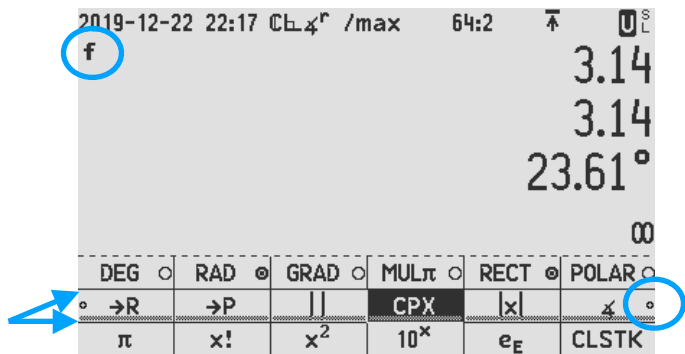

4. (2) and (3) should not be activated at the same time, I will add checkbox options to be able to activate either or both.

4. It is also possible to directly access the shifted function keys without first pressing the shift key, by holding in the function key Fx. This will cause the function to be displayed in the top left corner, and keeping the button in, will make it change to f(Fx) and g(Fx), eventually timing out to NOP.

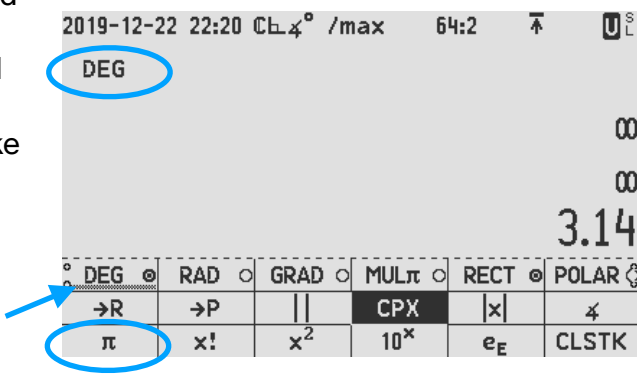

1. This can be seen as an extension of the NOP on the normal keys, first affording the opportunity to access the alternative functions on a key, then timing out to NOP.
2. For the function keys F1 through F6, a long press will similarly cycle from the primary Fx function, to the shifted f(Fx) to shifted g(Fx).
3. Additionally, double tap of Fx provides a shortcut to the g(Fx) function, if enabled in CFG.

5. A pre-packed assign profile to change the shifts is selectable in the PPP menu on g[1].

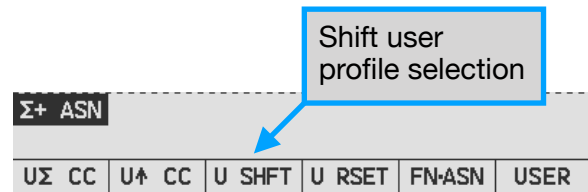

The [U SHFT] package re-maps the standard SIN, COS and TAN keys, to TRIG, F & G respectively, similar to WP43S.

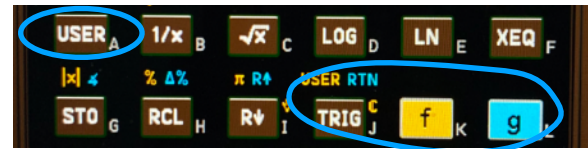

After remapping, the USER command toggles between User mode and Normal mode.

Note this shift function will only work in USER mode.

In this mode, [USER] is mapped to the top left key in both USER mode and normal mode and this enables rapid and easy switching between USER mode and Normal mode by simply using the [Σ+] button.

In progress



TAM layout



ALPHA Layout

19. Full BLUE key Layout 42B for unmodified DM42

LAYOUT 42B is the layout automatically applied to the DM42 firmware.

It differs from the "ideal" Layout 1B which is automatically assigned to the simulator.

The main advantage of Layout 42B is that the yellow labels on the WP43C allocation better correspond with the DM42 hardware yellow labels, which of course cannot be changed.

Layout 42B is a better fit to the unmodified DM42 keyboard layout.

The obvious problem is the lack of blue labels on the unmodified DM42.

The lack of labels can be addressed in a temporary way as follows:

1. Print a label, cut it out and overlay over the keys. This is a difficult process which does not often result in a nice template.
2. Print this page in colour and keep it around for a peek at what the blue labels are.

This method relies on looking at the layout when you need it, and eventually remembering the commonly used blue functions.

3. Use the HOME menu legend of which keys are where.

HOME reaches the g-key legend.

This method also relies on eventually remembering the commonly used blue functions.

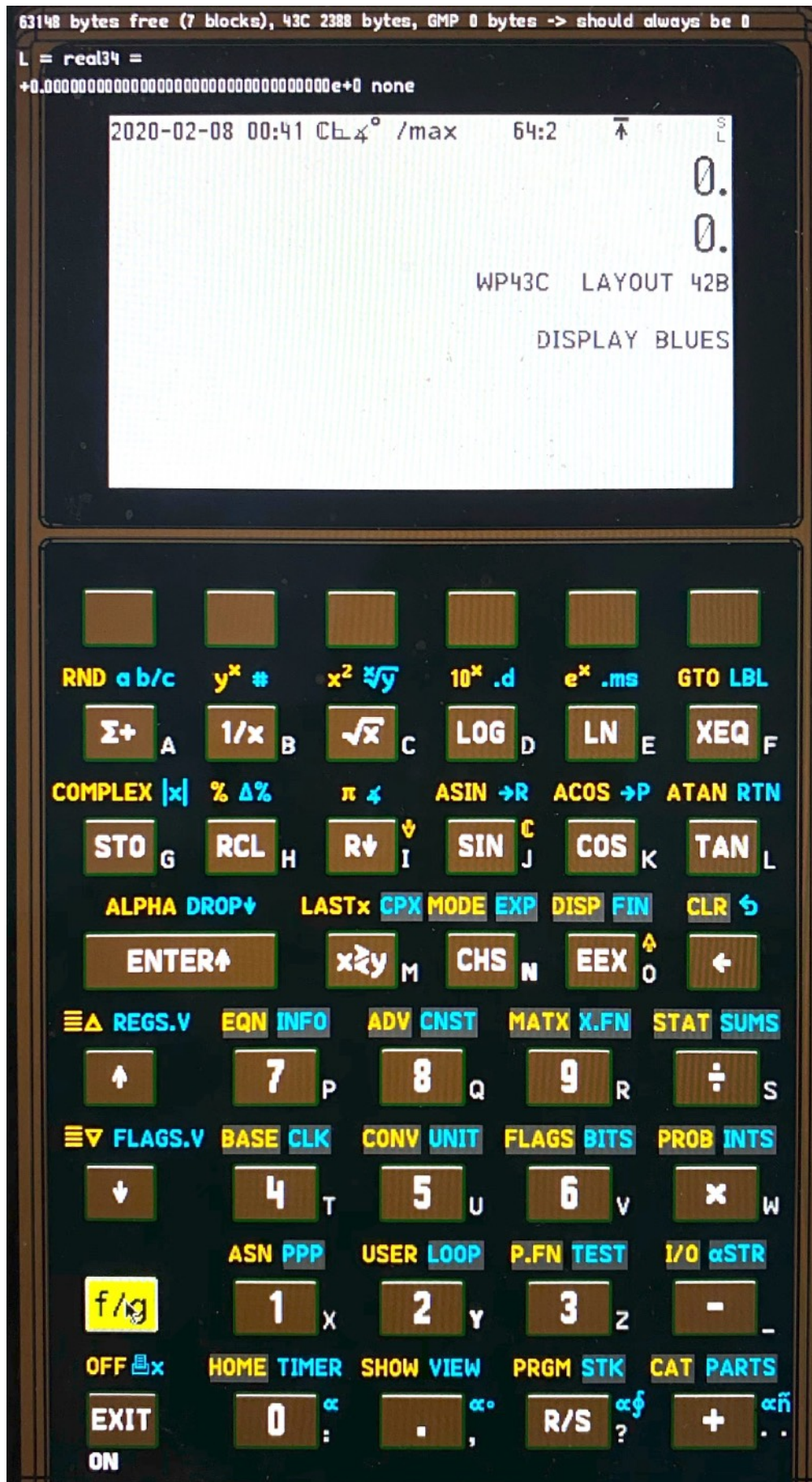

20. INFO menu

WHO?	VERS?	DIM?	±∞?	αPOS?	αLENG?
LocR?	FLASH?	ULP?	NEIGHB	SDIGS?	BATT?
SSIZE?	MEM?	RM?	SMODE?	WSIZE?	KTYP?

i Dflt?	eRPN?	HOME?	αHOME?	
---------	-------	-------	--------	--

A menu screen was added to the standard INFO menu, to host the additional WP43C settings.

i Dflt?	Input default type	0=Long Integer/REAL/Short Integer (default) 2=REAL, 4=Complex, 6=Short Integer 7=Long Integer
eRPN?	eRPN	0=RPN, 1=eRPN
HOME?	HOME	1=HOME base menu, 0=WP43S way
aHOME?	ALPHA HOME	1=ALPHA HOME base menu, 0=WP43S way

Pressing the softkey results in a value pushed to the stack, in X. The coding of these values are as follows:

21. GRAPH

The GRAPH function is located in the X.FN menu.

A graphing function is provided, and this will plot the function described by an RPN function.

The details of this operation will only be clear once the RPN programming is available.

Below example is done with a hard programmed emulated RPN function and it is expected that user programmed RPN functions with labels would be used in the same way.

:

Simulated RPN function calculated below:

```

01 LBL C
02 RAD
03 STO 99
04 SIN
05 RCL 99
06 /
07 RET
    
```

Note this is not WP43C code, it is a typical

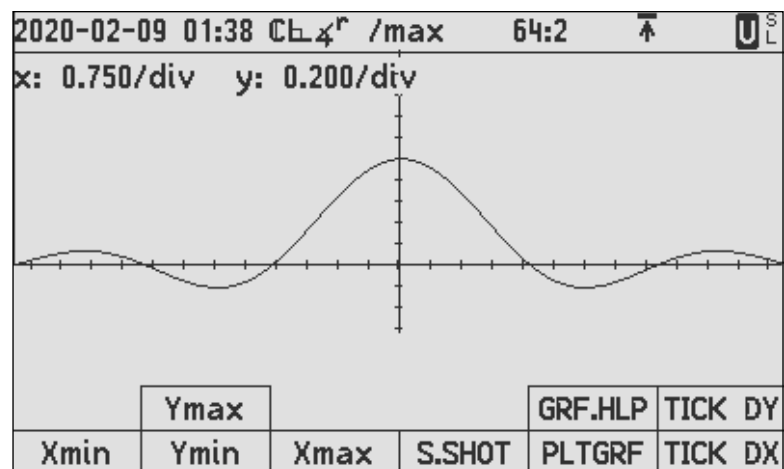

22. New Functions/modes/settings not in WP43S

Name	Type	Location	Location2	Description
SIG n	Display format mode	<u>HOME</u>	<u>DISP</u>	Similar to FIX, maintaining n significant digits while zeroing all other. Application: Engineering. Using analogue measurement from thermometer, ruler, ammeter, etc. Analogous to accuracy of slide rule.
UNIT n	Display format mode	<u>HOME</u>	<u>DISP</u>	Similar to ENG: Display k instead of $\times 10^3$, M instead of $\times 10^6$, n instead of $\times 10^{-9}$, etc.
>>LI	Command	<u>HOME</u>	<u>INTS</u>	Change number type
SI<<	Command	<u>HOME</u>	<u>INTS</u>	Change number type
>LI<>SI	Command	<u>HOME</u>	<u>INTS</u>	Change number type
.ms	Command	<u>CONV</u>	[g]LOG	Convert to between d.ms, h.ms and current angle mode.
HOME	Setting	<u>MODE, CFG</u>		HOME / MYMENU selection
αHOME	Setting	<u>MODE, CFG</u>		α HOME / My α selection
COMPLEX	Function	<u>CPX</u>	L1B: f(Enter) L42B: f(Enter)	HP42S compatible COMPLEX function.
CC	Function	<u>CPX</u>	L1B: f(Enter) L42B: f(Enter)	HP42S compatible COMPLEX function.
mm.Hg→Pa	Function	<u>UNIT</u>		Unit conversion added
Pa→mm.Hg	Function	<u>UNIT</u>		Unit conversion added
∠	Function	<u>HOME</u>	L1B: g[STO] L42B: g[R]	Complex angle. Temporary implementation. Uses stack: Change X to complex by adding 0+i0, change to polar, DropY, restore polar mode. Code: 0 0 CC + POLAR CC DROPY
STO Z, V, I	Command	<u>ELEC</u>		Store triple registers in 90-92, 93-95, 96-98
RCL Z, V, I	Command	<u>ELEC</u>		Recall triple registers 90-92, 93-95, 96-98
V/I	Function	<u>ELEC</u>		Do triple register divide for Ohm's Law
IxZ	Function	<u>ELEC</u>		Do triple register multiplication for Ohm's Law
V/Z	Function	<u>ELEC</u>		Do triple register divide for Ohm's Law
X-> BAL	Function	<u>ELEC</u>		Create balanced ABC quantity from X, into X, Y, Z
 	Function	<u>ELEC</u>		Do X register parallel with Y register
Y->D	Function	<u>ELEC</u>		Do star to delta impedance calculation
D-Y	Function	<u>ELEC</u>		Do delta to star impedance calculation

Name	Type	Location	Location2	Description
abc->012	Function	<u>ELEC</u>		Do three phase to symmetrical components
012->abc	Function	<u>ELEC</u>		Do symmetrical components to three phase
e^{∠θi}	Function	<u>ELEC</u>		Do Euler's formula with theta in X register
GRAPH	Menu	X.FN		Graph menu
PLT.GRF	Command	GRAPH		Plot a graph using an RPN function
S.SHOT	Command	GR APH		Screenshot of graph saved to /SCREENS

L1B: Keyboard layout for simulator and DM42 keyboard label overlay

L42B: Keyboard layout for DM42 compatible

23. Simulator Operation

The following keys operate the simulator:

FN1	FN2	FN3	FN4	FN5	FN6
add	inv	sqrt	log	ln	xeq
mem	rcl	down	sin	cos	tan
ENTER	w	neg	eex	BACK	
Up	7	8	9	/	
Dn	4	5	6	*	
Lshft	1	2	3	-	
Esc	0	.	\	+	

Keypresses



h to “hardcopy” screen to clipboard.

In addition to the a, v, q, o, ... letters used for keyboard control, there is now SHFT-A through SHFT-Z which are mapped to the simulator “A” through “Z”. SHIFT-1 through SHIFT-0 on the keyboard is mapped to the simulator 1 through 0 (except 8).

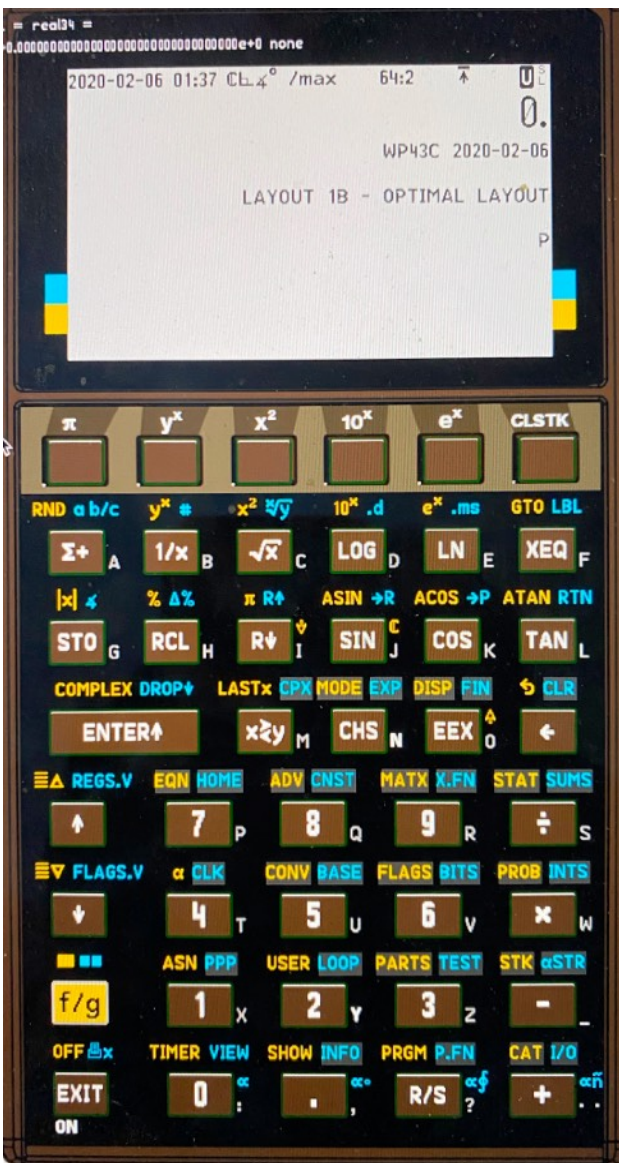

24. WP43C simulator photographs compared with other calculators

L = real16 =
+0.00000000000000e+0

Needs to be updated

WP43C L2 (DM42) (ON SCALE)

L = real16 =
+0.00000000000000e+0

Needs to be updated

WP43C L1A (Optimal) (ON SCALE)

L = long integer =
1

Needs to be updated

ALPHA MODE (ON SCALE)

Σ- 1/x √x LOG LN XEQ

HP42S (ON SCALE)

Σ- 1/x √x LOG LN XEQ

DM42 (ON SCALE)

Σ- 1/x √x LOG LN XEQ

HP32SII (ON SCALE)

A HYP-1 B SIN-1 C COS-1 D TAN-1 R<->P a% %

WP43C overlay (ON SCALE)

PRINT I/O MODES MEMORY LIBRARY PREV

HP48SX (not to scale)

FN= ISG RTN x^y

HP35s (ON SCALE)

25. Keyboard overlay



A keyboard overlay design is in process of being g designed.

Inautilus is driving this effort. The latest mockups are being circulated for comment.

Note that these designs are NOT close final and currently stands at layout and fonts selection tests.

26. Resources and references

Tidied up. Added new links in red.

Note the relevant project WP43S / WP43C links below:

- Main WP43S [sourceforge](#) project page.
- Walter's 43S News on [SwissMicros Forum](#).
- Paul Dale's 43S Assistance request on [HPMuseum forums](#).
- [Walter's post on SwissMicros Forum on 43S hijacking](#).
- WP43S code on [Gitlab](#).
- WP43C code on [Gitlab](#).
- [DMCP interface description on SwissMicros site](#).
- John Boyden's Mac install [post](#) of 6 May 2019.
- Hoverbeek's Mac install follow up [thread](#).
- Jaymos's HP Keyboard [comparisons](#).
- Jake Schwartz's HP Keyboard [comparisons](#).
- Pahhc Keyboard [comparisons](#) from HHC2000.
- Richard J Nelson's eRPN [discussion](#).
- [Hans Klaver's RPN tutorial or on wayback machine RPN](#). (Search "Entry RPN").

27. Chronological edits and changes since 2020-01-01

2020-01-01

FIXED: Dani reported: Bugs in the glyphs code in softmenu.c

FIXED: "ALL 0" does not show the "0"

FIXED: Elec formats: if real is used a= is not written.

Added sample longintREAL data in registers 10->13, for the 3 cubes = 3 problem.

Changed FGDOTS and FGLINE to fgDOTS and fgLINE

Changed ELEC2: V/Z to 3V/3Z

Changed Pa->mmHg and SB Home - were too long for catalog

Changed long items' catalog text, shorten or use short space. Eg. EM3 with CONV UP

FIXED GAPO not showing.

FIXED: Remove settings SH.3t, SH.4s from catalog

FIXED: << >>

ADDED special functionality for >R and >P. If a complex number is on X, it rather does RECT or POLAR. Improvement: We need to make >R & >P more intelligent as they are taking up valuable keyboard space. My proposal is the >R must check if X = complex number. If it is complex, the >R will rather call RECT. Same for >P and POLAR. I suggested this months ago. Walter clearly doesn't want to.

ADDED: Draw diagonal line across the softkey if there is no fnXXXX in items.

CHANGED: keys & menus to Layout 1B:

- Moved d.ms from g[sqrt] to menu MODE to be together with DEG/RAD/...

- Placed nth-root-of-y on g[sqrt] (key 3, top row)

- Moved SAVE from g[1] to the I/O menu to be with LOAD etc.

- Moved ASN menu (43C assign) from f[1] to g[1]

- Placed ASSIGN (43S future assign) to f[1]

- Moved UNIT from g[5] to a sub menu inside CONV

- Placed BASE on g[5]

CHANGED MENU: Menu changes

- Move MULpi to F4 in menu CONV

- Removed INTS and BITS menus from BASE as it is easy enough to get them on g[6] and g[x].

- In BASE menu, re-arranges settings to line f and convert functions to primaries

- In BASE menu, change >SI to have double functionality [LI <> SI] which changes from real to LI, and if LI to SI| and if SI to LI.

- In BASE I added the A-F keys, as I find I change between BASE and INTS all the time for that reason.

- In BASE: I questioned whether [->SI] is needed as there is also >Hex, >BIN ... the conclusion it is not needed

- In BASE menu, Make a BASE, >>LONGINT button. I changed ">SI" to be "R>L<>SI" which is the missing conversion from Real to Longint; then back and forth between Longint to shortint; and if shortint, to longint.

- In CONV, added >h.ms

LAYOUT 2: DM42

SAVE removed from g[1]

ASSIGN ASN on [1] as per Layout 1B. The menu is now on blue.

UNIT removed from g[5]

INFO g[7] swapped with VIEW g[.] for two reasons: 1. I use the emulator L1B a lot and I frequently get confused on the DM42 with INFO on g[7]. 2. I feel that VIEW (View a register) sits nicely next to REGS.V (views many registers).

2020-01-13

UPDATED: gitignore to allow exe file.

FIXED: "mass" to be "Mass"

ADDED: .ms

- .ms: Make h.ms: .ms and let this button cycle: -> d.ms -> h.ms -> .d and again

- .ms: h.ms replace with .ms

- .ms: Remove .d. There is a .d key right next door.

FIXED: SIGFIG Bug: 0.757 SIG 2 produces 0.767 instead of 0.757

FIXED and reported: 43S: RCL 5 ENTER does not work

FIXED sample Sum of Cubes = 3 data, which was not entered as longings but reals. R10-R13

ADDED the sum of cubes = 42 constants to registers, for testing purposes. R14-R17

FIXED: Change name of RM to RMODE (rounding mode)

FIXED: STAT entry needs n: add ITM_NSIGMA

ADDED: UNDO. Use Martin's Restorestack. It is incomplete.

FIXED: line up of longints in stack.

FIXED Reconsider << >>. Reported in 43C. Removed "CONFIRMED" from << and >>
 FIXED: Dani's HMS "If structure" after Testsuite build import wa fixed;
 FIXED: LastX fixed for fnJM
 FIXED: TRIG menu, remove Multpi, replace with d.ms. Change RECT with >R and POLAR with >P. These are the same as keyboard, therefore if REALs, it will change X and Y, and if X is complex, it will do RECT and POLAR. It is for the USER mode with shifts, where the >R and >P is not available on keys.
 CHANGED: Renamed >>L to ->L and S<< to S<-
 ADDED: Added .d to fnJM and index.func
 ADDED: FN KEYS: temporary fix to have g(FN) keys hand eei 9
 ADDED: The various conversions to INTS menu.
 ADDED: .ms to CONV menu
 FIXED. NIM GAP spacing dynamically change:
 Gap = Per gap setting for real or longint
 Gap = 2 fixed for SI: HEX and BASE 4
 Gap = 4 fixed for SI: BIN
 Gap = 3 fixed for SI: OCT
 Gap = 3 fixed for SI: DEC and other bases

Changed default setup to: DENMAX=32, DENFAC. Stack 8, ALL3, LEAD0, CPXRES, DANGERFLAG,
 Changed x! Limit to higher
 Reinstated the longer longint length
 Revised GRAPH Limits to more precision and spacing.

2020-02-01

- The changes to the HOME menu sequence can be summarised:
 - Top rows: angle modes were reduced to 3 only, i.e. DEG/RAD/d.ms.
 - Top rows: j added. I will make this sensitive to the setting, i.e. i or j
 - Top rows: RECT/POLAR remains, complete with radio button indicating the mode.
 - Top rows: remain constant over all five screens.
 - Bottom rows: replicate the four f-shifted top row exp functions on primaries. No HP had both x^2 and sort(X) on primaries but this one does.
 - Bottom rows: have pi and CLSTK instead of f[RND] and f[GTO] respectively.
 - Bottom row is active when no menu is displayed.
 - Bottom rows: remain constant over all five screens.
 - Middle row HOME 1: Has >R and >P because Layout42B does not have blue labels showing >R and >P. This is the new context sensitive >R and >P which works differently for complex and real types.
 - Middle row HOME 1: Has || to save finding X.FN Up to get ||. And x! To save finding PROB menu.
 - Middle row HOME 1: Has |x| and angle as this is also on hidden blue labels on the Layout42B.
 - Middle row HOME 2: Has all the DISP modes handy.
 - Middle row HOME 3: SI prefixes.
 - Middle row HOME 4: Conveniently has menus, TRIG (on no key), EXP/CPX/X.FN all on blues, MyMenu (not on key) and ELEC on X.FN.
 - Middle row HOME 5: INTEGER type conversions/functions.
- INFO: The diagonal line across each softkey that is not yet implemented was taken over by 43S.
- CHANGED: Numerical input GAP setting changed. It is now dynamically changing, i.e. Gap=2 for SI: HEX and BASE 4; Gap=4 for SI: BIN; Gap=3 for SI: OCT; Gap=3 for SI: DEC and for other bases. 43S does not want this.
- CHANGED the functionality of >R & >P in the HOME menu and on the keyboard as follows: If a complex number in X, it does RECT or POLAR MODE change. If not, normal >R or <P will be performed on X & Y. (<https://forum.swissmicros.com/viewtopic.php?f=2&t=1816&p=11834&hilit=RECT+POLAR#p11834> request 4, WP43S did not respond).
- ADDED: .ms to CONV menu and to top row. .ms is a function in place of d.ms on g[LN]. .ms cycles and converts to d.ms, h.ms and current angle mode.
- ADDED: FN KEYS: according to the primary line of the HOME menu, also when no softmenu is showing.
- CHANGED: line up the display of longints in stack and REGS.V. 43S did not confirm if they will change it like this.
- ADDED: UNDO. Activation of incomplete UNDO function code. Works well, but not implemented all over.
- CHANGED: Change name of RM to RMODE (rounding mode)
- ADDED: Additional function RND identical to ROUND, to fit on the keyboard. Retaining both ROUND in menu and RND on keyboard.

- ADDED: Placed RND on key f[E+].
- CHANGED: default calculator setup to: Stack 8, ALL3, LEAD0 set, CPXRES set, DANGERFLAG set.
- CHANGED: x! Increased from the limit of 450! to 1388!. It is experimental.
- CHANGED: longint length from 3328 binary digits to 15000 (4500 decimal digits). This is experimental and may well be reduced to 2500 decimal digits. The previous WP43S longint maximum some time ago was set to 8192 (2450 decimal digits) before this was changed to 3328 which is 1000 digits.
- CHANGED: the GRAPH Limits to display more precision and better spacing.
- ADDED: a screen shot / snapshot button for the GRAPH menu, to output the produced graph to /SCREENS.
- ADDED: SHIFT-DISP (standard DM42) for screen shot. Get another trigger button for screen dump, maybe double EXIT. The current trigger button does a NOP which spoils the graph.
- CHANGED: On Layout42B, the yellow label determines that CLR must be on yellow and UNDO on blue. On Layout1B it is the other way around.
- ADDED: SI prefix commands, pico, nano, micro, mille, kilo, Mega on one line of the HOME menu
- CHANGED: Dani's suggestion: Moved "s->year" and "year->s" from UNIT to CLK? CLK is a combination of setup type and conversion type functions. Conversions on the first page and setup on the second.
- ADDED: To DOC: make list of functions incl Lastx and UNDO
- ADDED some temporary sample data in registers 10 through 20:
 - the sum of cubes = 42 constants to registers, for testing purposes. R14-R17
 - the sum of Cubes = 3 constants to registers, for testing purposes. R10-R13
 - To use, type: RCL11 3 [y^x] RCL12 [y^x] RCL13 [y^x] + +
 - Pi fraction to 37 digits: http://qin.laya.com/tech_projects_approxpi.html
 - To use, type: RCL19 RCL20 / to get 37 digits of pi, but only 34 will be in the REAL stack.