

# Fundamentals of Railway Curve Superelevation

## with Explanation of Curve Radius and Degree of Curve

By Jeffrey G. Hook

Original April 20, 2010, Revised January 24, 2025

### Centrifugal Force.

Railway locomotives and cars, hereafter referred to as rolling stock, when rounding a curve may be considered as coming under the influence of centrifugal force. Centrifugal force commonly defined as: 1. The apparent force that is felt by an object moving in a curved path that acts outwardly away from the center of rotation. 2. An outward force on a body rotating about an axis, assumed equal and opposite to the centripetal force and postulated to account for the phenomena seen by an observer in the rotating body. For this article the use of the phrase centrifugal force or the abbreviation  $F_c$  shall be understood to be an apparent force as defined above. It shall also be understood that unless specified otherwise when the word curve is used it refers to a circular curve or simple curve, that being a curve of constant radius.

### Suspension Systems Considered.

Only rolling stock suspension systems of conventional design, circa 1980, are considered for this article. Active or passive rolling stock center of gravity modifying devices or schemes such as tilting car bodies or trucks, or pendulum suspension schemes are not applicable to and the explanation of which is beyond the scope of this article.

### Effect of Centrifugal Force.

When rolling stock rounds a curve and the rails of the track are at the same elevation, the plane of track is horizontal, the combination of the weight of the rolling stock  $W$  and the centrifugal force  $F_c$  will produce a resultant force  $F_r$  that does not coincide with the center line or axis of track. The foregoing results in a non-equilibrium condition where the downward force on the outside rail of the curve will be greater than the downward force on the inside rail. The greater the velocity or the smaller the radius of the curve becomes the resultant force  $F_r$  will move farther away from the center line or axis of track. Overturning conditions are imminent when resultant force  $F_r$  approaches and crosses over the outside rail. The foregoing description and following drawings are a simplification of the circumstances and do not take into consideration the effect of the lateral displacement of the center of gravity that may be permitted by the suspension system of the rolling stock.

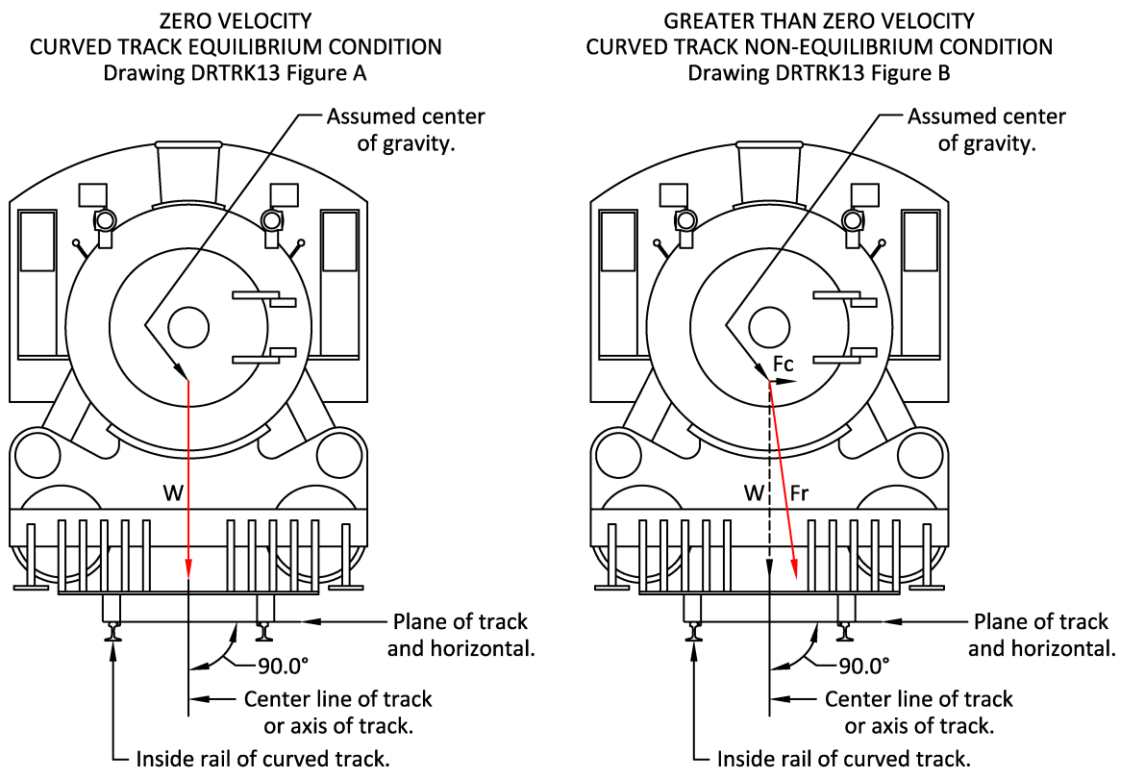

To compensate for the effect of centrifugal force  $F_c$  the plane of track may be canted by elevating the outside rail of the curve above the inside rail thereby moving the center of gravity of the rolling stock laterally toward the inside rail. The foregoing is typically referred to as superelevation or in United States railway practice simply as elevation when referring to a curve. If the combination of the lateral displacement of the center of gravity provided by the cant of track, velocity of the rolling stock and radius of curve is such that resulting force  $F_r$  coincides with the center line or axis of track, an equilibrium condition will be achieved where the downward force on the outside and inside rails of the curve will be the same. Drawing DRTRK13 Figures C and D illustrate this equilibrium condition and the fundamental relationship that exists where the angle of cant of track is the same as the angle of resultant force  $F_r$  from vertical.

GREATER THAN ZERO VELOCITY  
CURVED TRACK EQUILIBRIUM CONDITION  
Drawing DRTRK13 Figure C

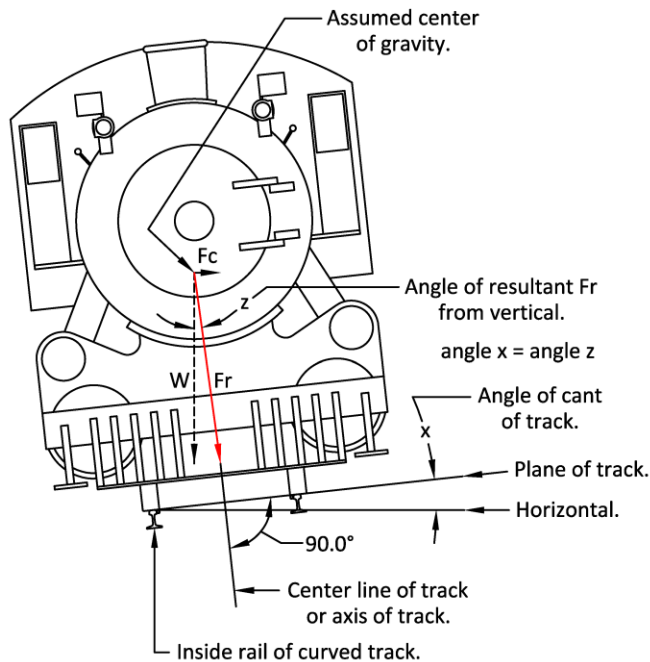

GREATER THAN ZERO VELOCITY  
CURVED TRACK EQUILIBRIUM CONDITION  
Drawing DRTRK13 Figure D

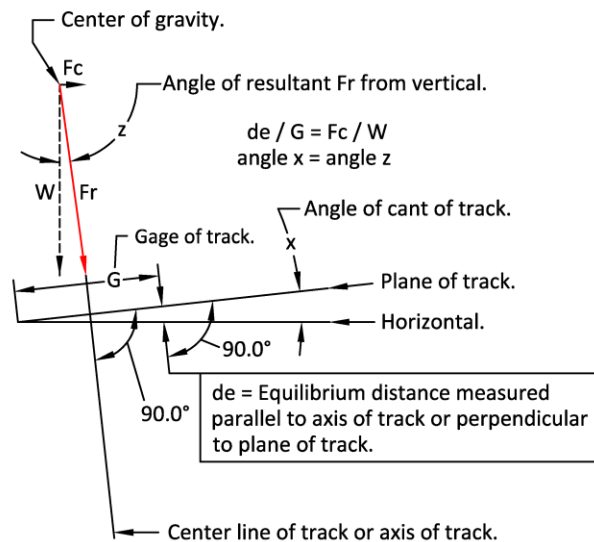

From the law of weight of bodies:

$$W = M * g \dots \text{Formula 1.}$$

then:

$$M = W / g$$

where:

$W$  = Weight of body in pounds.

$M$  = Mass of body in pounds.

$g$  = Acceleration due to gravity taken as 32.16 feet per second per second.

From the law of centrifugal force:

$$F_c = M * v^2 / r \dots \text{Formula 2.}$$

where:

$F_c$  = Centrifugal force in pounds.

$v$  = Velocity of body in feet per second.

$r$  = Radius of rotation of body in feet.

From Formulas 1 and 2 may be derived the following:

$$F_c = W * v^2 / (g * R) \dots \text{Formula 3.}$$

$$F_c / W = v^2 / (g * R) \dots \text{Formula 4.}$$

$$f_c = v^2 / (g * R) \dots \text{Formula 5.}$$

and for equilibrium condition where angle  $x = \text{angle } z$ :

$$de / G = F_c / W \dots \text{Formula 6.}$$

$$de = G * v^2 / (g * R) \dots \text{Formula 7.}$$

where:

$F_c$  = Centrifugal force in pounds.

$f_c$  = Centrifugal force per unit of weight of rolling stock.

$W$  = Weight of rolling stock in pounds.

$R$  = Radius of center line of curve in feet.

$de$  = Equilibrium distance in feet measured parallel to axis of track or perpendicular to plane of track.

$G$  = Gage of track in feet.

**Application of Superelevation, Simplified Method.**

To achieve equilibrium condition for given circumstances of velocity and curve radius the angle of cant of track from horizontal must be made equal to the angle of the resultant force from vertical. Although canting the plane of track by applying the calculated equilibrium distance  $d_e$  parallel to the axis of track will produce the exact angular relationship required, the foregoing is simplified by elevating the outside rail of the curve vertically above the inside rail the same amount as that calculated for equilibrium distance  $d_e$  and referred to as equilibrium elevation  $E_e$  instead.

From Formula 7 is derived the following:

$$E_e = G * v^2 / ( g * R ) \dots \text{approximate} \dots \text{Formula 8.}$$

where:

$E_e$  = Equilibrium elevation in feet, approximate. (Note: The word elevation implies vertical measurement.)

$G$  = Gage of track in feet.

$v$  = Velocity in feet per second.

$g$  = Acceleration due to gravity taken as 32.16 feet per second per second.

$R$  = Radius of center line of curve in feet.

Thus superelevation may be practically applied by the use of a spirit level where a spacer block the thickness of equilibrium elevation  $E_e$  is applied to the bottom of one end and placed on top of the inside rail of the curve and the unmodified bottom of the other end of the spirit level is placed on top of the outside rail. The outside rail of the curve is then raised by canting the track until the spirit level bubble becomes centered in its vial.

GREATER THAN ZERO VELOCITY  
CURVED TRACK APPROXIMATE EQUILIBRIUM CONDITION  
PRACTICAL APPLICATION OF SUPER ELEVATION  
Drawing DRTRK13 Figure E

GREATER THAN ZERO VELOCITY  
CURVED TRACK APPROXIMATE EQUILIBRIUM CONDITION  
PRACTICAL APPLICATION OF SUPER ELEVATION  
BY SPIRIT LEVEL  
Drawing DRTRK13 Figure F

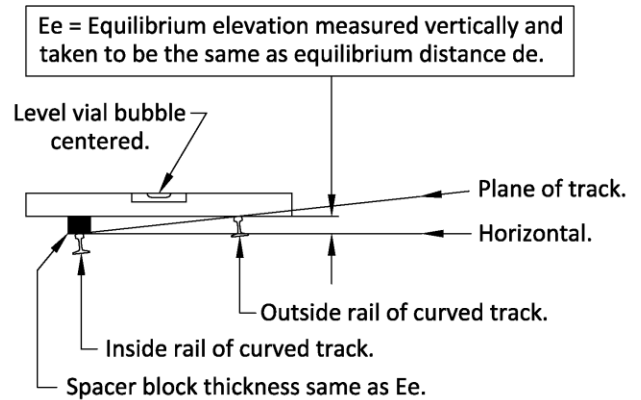
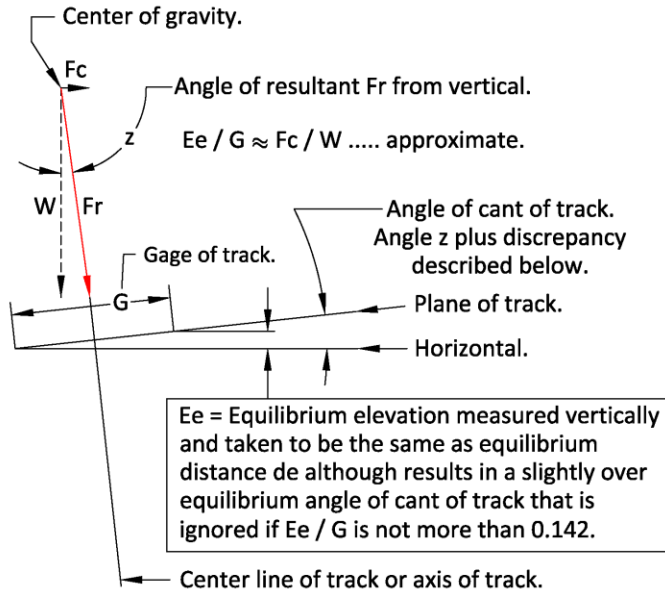

**Limitation of Approximation.**

Applying the result of Formula 8 vertically instead of parallel to the axis of track produces a cant of track that is greater than what will provide equilibrium condition for the velocity and radius entered in the formula. For a railway employing standard 56.5 inch gage track and a curve superelevated 8 inches vertically the superelevation distance if measured paralleled to the axis of track will be 8.081 inches. This discrepancy is considered negligible and ignored for this gage of track where superelevation is typically limited to not more than 8 inches. For other gages of track the approximate result of Formula 8 may also be tolerated if  $E_e / G$  is not more than 0.142. The foregoing derived from  $8 / 56.5$ .

**Selected A.R.E.M.A. Information on the Subject of Superelevation.**

Presented in outlined boxes following are excerpts from the Manual or published proceedings of annual conventions of the American Railway Engineering and Maintenance-of-Way Association, later known as the American Railway Engineering Association and currently again known as the American Railway Engineering and Maintenance-of-Way Association. The intent of the presentation of these excerpts being to illustrate in brief the organizations evolution on the subject of superelevation.

**A.R.E.M.A. 3<sup>rd</sup> Annual Convention 1902.**

<p style="text-align: center;"><b>2. MAINTENANCE OF SURFACE.</b></p> <p>(a) Elevation of Curves, with special consideration as to amount and beginning and end of elevation, and as modified by location of curve and conditions of traffic:</p> <p>Recommendations: The inner rail shall be maintained at grade. Your Committee advises that the approximate formula,</p> $E = \frac{G V^2}{32.16 R}$ <p>in which,</p> <p>E = elevation in feet,  G = standard gauge, 4.708 feet,  V = velocity in feet per second,  R = radius of curve in feet.</p>	<p>will give essentially correct theoretical elevations for the outer rail of curves, and is recommended for ordinary practice, but must be modified to suit special conditions.</p>
--	--

In the 1902 excerpt the variables “E = elevation in feet” and “V = velocity in feet per second” and the phrase “essentially correct theoretical elevations” are those under equilibrium conditions. The formula in the excerpt  $E = G * V^2 / ( 32.16 * R )$  is equivalent to Formula 8 and is also noted as being approximate due to the application discrepancy previously described. The gage of track variable G is specified as being 4.708 feet or 56.5 inches, although except for the approximation, this formula may be considered universal in nature as other gages of track may be entered for variable G.

**A.R.E.M.A. 6<sup>th</sup> Annual Convention 1905.**

<b>MAINTENANCE OF SURFACE.</b>	
<p>(a) Elevation of Curves, with special consideration as to amount and beginning and end of elevation, and as modified by location of curve and conditions of traffic:</p> <p>The approximate formula,</p> $e = \frac{Gv^2}{32.16 R}$ <p>in which</p> <p>e = Elevation in feet,  G = Gauge of track,  v = Velocity in feet per second,  R = Radius of curve in feet,</p> <p>will give essentially correct theoretical elevation for the outer rail of curves, and is recommended for ordinary practice, but must be modified as noted below to suit special conditions.</p>	<p>For greater convenience the formula above may be further reduced by substituting</p> $v = \frac{V5280}{3600},$ <p>G = 4.708,  <math>R = \frac{5730}{D}</math> (approx.),  <math>e = 1.12 E,</math></p> <p>in which</p> <p>V = Velocity in miles per hour,  D = Degree of curve,  E = Elevation of outer rail in inches,  <math>E = .00066 DV^2.</math></p> <p>and whence</p>

In the 1905 excerpt the formula  $e = G * v^2 / ( 32.16 * R )$  is improved upon “for greater convenience” by introducing a constant that provides for the following:

- E = Elevation of outer rail in inches instead of in feet.
- D = Degree of curve 100.0 foot chord basis instead of entering curve radius in feet.
- V = Velocity in miles per hour instead of entering velocity in feet per second.
- G = Gage of track taken as 4.708 feet thereby rendering the formula applicable only to standard 56.5 inch gage track.

----- Derivation of constant -----
Velocity     Track gage     Degree of curve     Gravity
----- approximate -----

Note: See middle of page 17 for beginning of additional explanation of curve radius and degree of curve.

$$0.000659 \approx ( 5280 / 3600 )^2 * 12 * 4.708 * ( 1 / 5730 ) * ( 1 / 32.16 )$$

$$E = 0.00066 * D * V^2 \dots \text{approximate} \dots \text{applicable only to 56.5 inch gage of track} \dots \text{Formula 9.}$$

Formula 9 includes two approximate elements. Once again E is applied vertically. Additionally the precise relation between degree of curve 100.0 foot chord basis and curve radius in feet is,  $R = 50 / \sin ( D / 2 )$ . Therefore a 1 degree curve 100.0 foot chord basis equals more precisely although still approximately a curve radius in feet of 5729.6507.

SPEEDS OF TRAINS ON CURVES AND TURNOUTS.

F. S. Stevens and G. J. Ray, Special Committee.

Your Committee reports that it has made a study of speeds through turnouts and around curves, has made calculations and has prepared diagrams showing the results of these calculations, which are presented here-with.

RELATION OF SPEED TO POINT OF INTERSECTION OF RESULTANT OF FORCES WITH PLANE OF TRACK.

Let  $M$  = the mass of a body,  
 $g$  = the acceleration of gravity,  
 $W$  = the weight of the body.

From the law of the weight of bodies,  
 $W = M g$ .

Let  $R$  = the radius of rotation,  
 $v$  = the velocity in feet per second,  
 $C$  = centrifugal force.

From the law of centrifugal force,

$$C = \frac{M v^2}{R};$$

Hence 
$$\frac{C}{W} = \frac{v^2}{R g} \dots \dots \dots (1)$$

Let  $V$  = velocity in miles per hour,  
 $D$  = degree of curve.

Then 
$$v = \frac{5280 V}{3600},$$
  

$$R = \frac{5730}{D}, \dots \dots \dots (\text{approx.})$$

$g = 32.16$ .

Substituting these values in equation (1)

$$\frac{C}{W} = .00001167 D V^2 \dots \dots \dots (2)$$

$$\log = 5.067192 - 10$$

In following commentary of Steven's and Ray's work their formula and figure numbers are preceded by the initials S&R in order to differentiate them from other formulas and figures presented in this article.

Formula S&R 1 is improved upon for greater convenience by Formula S&R 2 that introduces a constant that includes the acceleration of gravity, allows for the entry of velocity in miles per hour instead of feet per second and the entry of degree of curve (100.0 foot chord basis) instead of curve radius in feet. Although similar to the A.R.E.M.A. formula of 1905, Formula S&R 2 does not include the gage of track and its result is that of  $C / W$ , that may be considered as either the centrifugal force developed per unit weight of rolling stock or the ratio between two sides of the force triangle having the sides labeled  $C$ ,  $W$  and  $F$  as illustrated in Figure S&R 1 below.

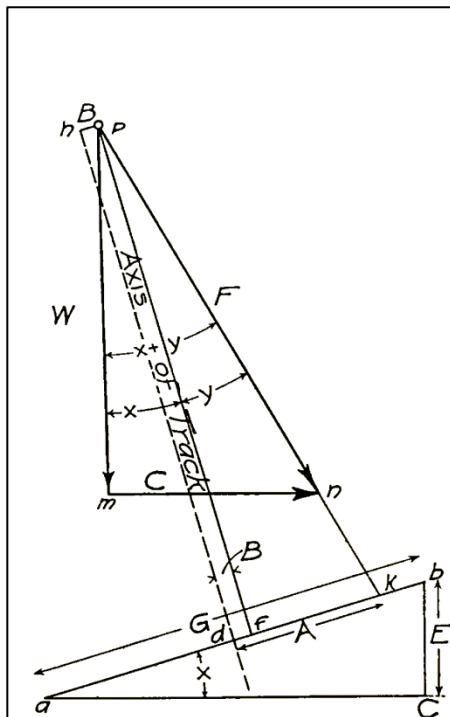

FIG. 1.

Let  $G$  = gage of track,  
 $E$  = elevation for curvature,  
 $H$  = height of center of gravity above top of rail,  
 $F$  = resultant of forces,  
 $A$  = distance from center of track to intersection of  $F$  with plane of track,  
 $B$  = distance from center of gravity to axis of track,  
 $x$  = cant of track = angle of axis of track with the vertical,  
 $y$  = angle of resultant of forces with axis of track.

In Fig. 1,  $ab = G$   
 $bc = E$   
 $hd = pf = H$   
 $pn = F$   
 $dk = A$   
 $hp = df = B$   
 angle  $bac = mpf = x$   
 and angle  $fpk = y$

From the right triangles

$$\sin x = \frac{E}{G} \dots \dots \dots (3)$$

$$\tan y = \frac{A-B}{H} \dots \dots \dots (4)$$

$$\tan (x + y) = \frac{C}{W} = .00001167 D V^2 \dots \dots \dots (5)$$

Figure S&R 1 illustrates an extreme under balanced non-equilibrium condition given that resultant force F when prolonged intersects the plane of track at k and is near to b that represents the reference point for the elevation of the outside rail of the curve. Also illustrated is an extreme condition of superelevation given that if distance G is taken to represent 56.5 inches, then by using the same drawing scale distance E represents 16.18 inches or more than twice what would typically be permitted for standard 56.5 inch gage track. Also illustrated is the lateral displacement of the center of gravity away from the axis of track and toward the outside rail that is the result of deflection of the suspension system of the rolling stock and lateral clearances of the rolling stock and track being taken up.

**STEVEN'S AND RAY'S FIGURE 1  
ORIGINAL ILLUSTRATION OF  
UNDER BALANCED  
NON-EQUILIBRIUM CONDITION**

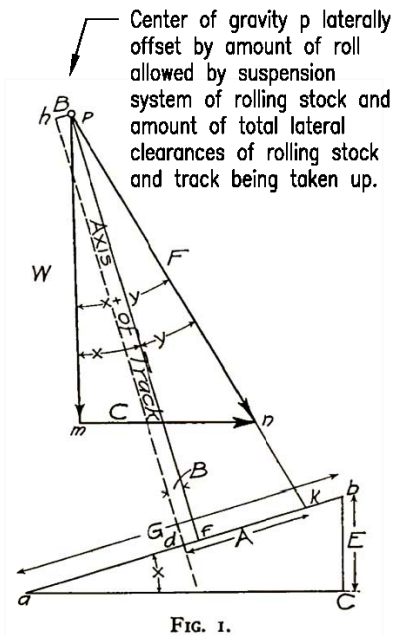

**STEVEN'S AND RAY'S FIGURE 1  
MODIFIED TO ILLUSTRATE  
EQUILIBRIUM CONDITION  
Drawing DTRRK13 Figure G**

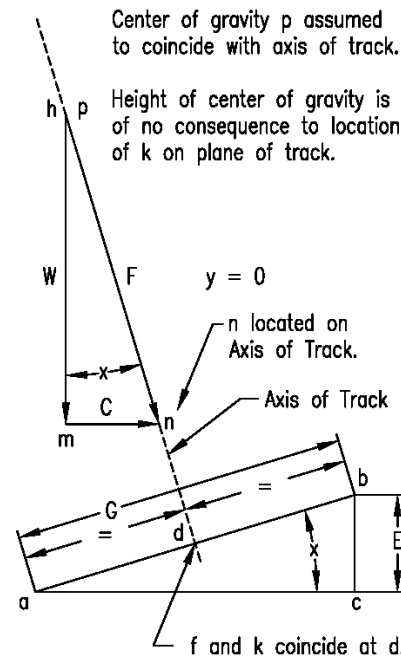

**STEVEN'S AND RAY'S FIGURE 1  
MODIFIED TO ILLUSTRATE  
ZERO VELOCITY OVER BALANCED  
NON-EQUILIBRIUM CONDITION  
Drawing DRTKK13 Figure H**

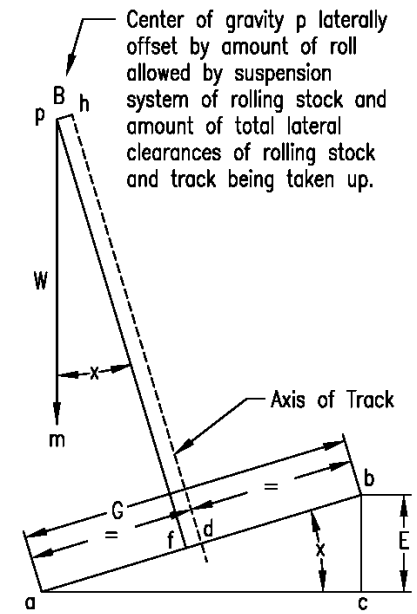

In Drawing DRTRK13 Figure G, Steven's and Ray's Figure 1 has been modified to illustrate equilibrium conditions where resultant force F coincides with the axis of track. Under equilibrium conditions the height of center of gravity is of no consequence in fixing the point where resultant force F intersects the plane of track. In Drawing DRTRK13 Figure H, Steven's and Ray's Figure 1 has again been modified although to illustrate an over balanced non-equilibrium condition that would occur if rolling stock stopped on a super elevated curve. Under this circumstance the lateral displacement of the center of gravity away from the axis of track will instead be toward the inside rail and again is the result of deflection of the suspension system of the rolling stock and lateral clearances of the rolling stock and track being taken up.

**Application of Superelevation, Trigonometric Method by Stevens and Ray.**

Steven's and Ray's Figure 1 graphical presentation of superelevation is complemented by their use of trigonometry for ascertaining elevation E that is free from the discrepancy of the simplified method previously described.

Knowing the ratio between the opposite side C and the adjacent side W of the force triangle, the angle of resultant force F from vertical may be ascertained by that portion of Formula S&R 5,  $\tan (x + y) = C / W$ . For equilibrium condition when resultant force F coincides with the axis of track  $y = 0$  then affectively Formula S&R 5 is,  $\tan x = C / W$ .

From the right triangles

$$\sin x = \frac{E}{G} \dots\dots\dots (3)$$

$$\tan y = \frac{A-B}{H} \dots\dots\dots (4)$$

$$\tan (x + y) = \frac{C}{W} = .00001167 D V^2 \dots\dots\dots (5)$$

Knowing the angle of resultant force F from vertical for equilibrium condition equals x, then the ratio between the opposite side E and the hypotenuse side G of the plane of track triangle may be ascertained by Formula S&R 3,  $\sin x = E / G$ .

For equilibrium condition A and B may be assumed to equal zero therefore in Formula S&R 4,  $y = 0$ . Also the height of center of gravity H is of no consequence.

TRIGONOMETRIC RELATIONSHIPS BETWEEN THE FORCE TRIANGLE AND THE PLANE OF TRACK TRIANGLE  
Drawing DRTRK13 Figure I

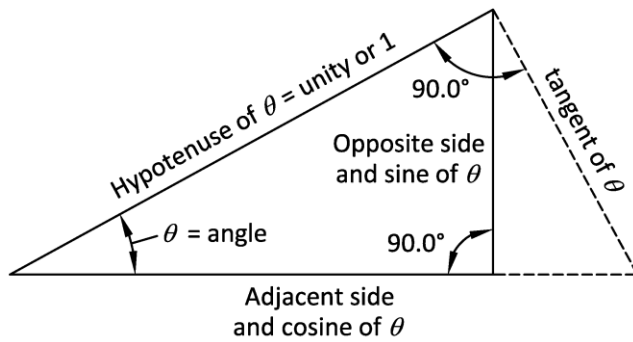

Drawing DRTRK13 Figure J

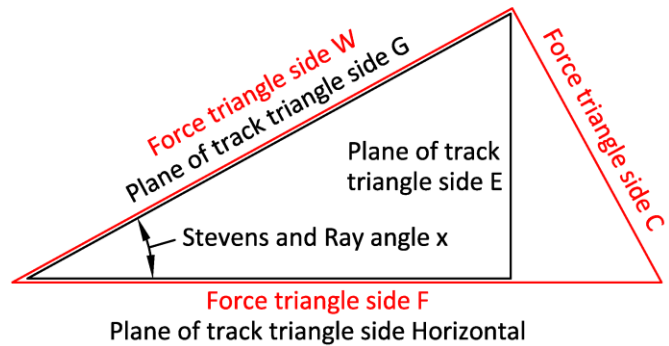

**Universal Formulas for Equilibrium Superelevation, Gage of Track Basis.**

From the work of Stevens and Ray have been derived Formulas 10 and 11 that are universal in nature by their applicability regardless of the gage of track and include minimal approximation due to their calculation or application.

$$Ee = G * \sin ( \tan^{-1} ( K_{10} * V^2 / R ) ) \dots \dots \text{Formula 10.}$$

$$Ee = G * \sin ( \tan^{-1} ( K_{11} * V^2 * D ) ) \dots \dots \text{Formula 11.}$$

$$K_{10} = ( 5280 / 3600 )^2 * ( 1 / 32.16 ) \dots \dots \text{Formula 10K.}$$

$$K_{11} = ( 5280 / 3600 )^2 * ( 1 / 32.16 ) * ( 1 / ( C / 2 / \sin 0.5 ) ) \dots \dots \text{Formula 11K.}$$

where:

where:

Ee = Equilibrium elevation of outside rail of curve in inches.

Ee = Equilibrium elevation of outside rail of curve in inches.

G = Gage of track in inches.

G = Gage of track in inches.

V = Velocity in miles per hour.

V = Velocity in miles per hour.

R = Radius of center line of curve in feet.

D = Degree of curve.

C = Length of chord in feet degree of curve is based on.

**Limitation of Curve Superelevation, A.R.E.M.A. 3<sup>rd</sup> Annual Convention 1902.**

The maximum allowable elevation of curves depends entirely on local conditions. On fast passenger roads, where crushed stone or other stiff ballast is used, a difference in elevation of 8 inches is successfully maintained, and your Committee recommends that for ordinary practice a maximum elevation of 8 inches shall be used, but that when greater elevation is required, speed shall be reduced until the 8 inches elevation gives satisfactory results.

The stability of the track ballast to resist disturbing forces may be one circumstance that limits maximum superelevation. Additional circumstances to be considered include when rolling stock is operated on a curve at less than equilibrium velocity or comes to a complete stop. Excess superelevation in these cases may lead to a downward force on the inside rail sufficient to damage it or cause derailment of rolling stock toward the center of the curve when draft force is applied to a train. Routine operation of loaded freight trains at low velocity on a curve superelevated to permit operation of higher velocity passenger trains will result in excess wear of the inside rail of the curve by the freight trains. Although the 1902 excerpt presents a succinct explanation of the rationale for determining maximum allowable superelevation, the dimension recommended has withstood the test of time given that as of 2011 the United States Federal Railroad Administration limits superelevation on standard 56.5 inch gage track to 8 inches on track suitable for passenger train operation at a velocity of not more than 30 miles per hour and limits super elevation to 7 inches on track suitable for passenger train operation at a velocity of not more than 90 miles per hour.

## Limitation of Curve Velocity, A.R.E.M.A. 3<sup>rd</sup> Annual Convention 1902.

It must not be understood that it is unsafe to run over a curve at a higher rate of speed than that for which it is elevated. A train may safely run 10 miles per hour over a curve which has no elevation. In the same manner a train may safely run 60 miles an hour over a curve elevated for a speed of but 50 miles an hour. Such an extreme should be avoided. It results in increased flange and rail wear and cost of maintenance. The curve can never ride perfectly and the danger of accident is increased.

Maximum velocity on a curve may indeed exceed equilibrium velocity, but must be limited to provide a margin of safety before overturning velocity is reached or forces are developed sufficient to damage or displace the outside rail of the curve. A velocity limit established in order to avoid the foregoing is generally referred to as maximum safe velocity or safe speed. Although operation at not more than what is typically considered to be a maximum safe velocity will avoid overturning of rolling stock or rail damage, a passenger riding in a conventional passenger car at that velocity will most likely experience centrifugal force perceived as a tendency to slide laterally on their seat creating in the passenger an uncomfortable sensation of instability. To avoid passenger discomfort maximum velocity on a curve is therefore further limited to what is generally referred to as maximum comfortable velocity or comfortable speed.

## Comfortable Velocity Presented by Stevens and Ray, A.R.E.A. 15<sup>th</sup> Annual Convention 1914.

Presented in the two outlined boxes following are additional excerpts from Steven's and Ray's work.

### SPEED AND UNBALANCED ELEVATION FOR CURVATURE.

The comfort of a passenger on a train, which passes over a curve or through a turnout at high speed, is not dependent on the height of the center of gravity of the engine which draws his train, or of the car in which he is riding, nor is it dependent on the point where the resultant of forces intersects the plane of the track.

But the comfort of the passenger is much affected by the condition of the track in the matter of surface and line, and the disturbed equilibrium of the passenger due to centrifugal force uncompensated by the cant of the track.

The relation of speed to the condition of the track cannot be reduced to formula, tabulated nor shown on a diagram, but the relation of equilibrium to speed can very readily be shown.

There are nearly as many opinions as there are individuals as to what constitutes a comfortable speed on curves; but by tabulating speeds which will produce a certain fixed degree of disturbance of equilibrium, we can at least furnish a basis for comparison between speed and comfortable riding.

Referring to Fig. 1, if  $y=3$  degrees, the track will lack sufficient cant to neutralize the centrifugal force by 3 degrees; a difference of 3 degrees in the cant of the track is very closely equivalent to a difference of 3 inches in elevation of the outer rail. Hence, if the amount of discomfort can be measured by the degree of angle, which the resultant of forces makes with the axis of the car, it can be measured by number of inches of unbalanced elevation. In other words, a passenger riding over track elevated 1 inch at a speed requiring an elevation of 4 inches, should experience the same amount of discomfort as when riding over track elevated 7 inches at a speed requiring an elevation of 10 inches.

Your Committee has calculated tables of speeds of trains through curves and turnouts with unbalanced elevations of 3 inches. These calculations were made from the formulas

$$\sin(x+y) = \frac{E+3}{56.5} \text{ and } V = \sqrt{\frac{\tan(x+y)}{.00001167D}}$$

in which  $E$  = actual elevation for curvature.

### SPEEDS OF TRAINS ON CURVES

Three Inches of Unbalanced Elevation.

Those Speeds of Trains on Curves having an Elevation of 3 Inches less than the Theoretical Elevation.\*

All Heights of Center of Gravity.

Degree of Curve	Actual Elevation in Inches								
	0	1	2	3	4	5	6	7	8
1°	67.5	78.0	87.2	95.6	103.4	110.7	117.6	124.1	130.4
1°30'	55.1	63.7	71.2	78.1	84.4	90.4	96.0	101.3	106.5
2°	47.7	55.1	61.7	67.6	73.1	78.3	83.1	87.8	92.2
2°30'	42.7	49.3	55.2	60.5	65.4	70.0	74.3	78.5	82.5
3°	39.0	45.0	50.4	55.2	59.7	63.9	67.9	71.7	75.3
3°30'	36.1	41.7	46.6	51.1	55.3	59.2	62.8	66.3	69.7
4°	33.7	39.0	43.6	47.8	51.7	55.3	58.8	62.1	65.2
4°30'	31.8	36.8	41.1	45.1	48.8	52.2	55.4	58.5	61.5
5°	30.2	34.9	39.0	42.8	46.2	49.5	52.6	55.5	58.3
6°	27.6	31.8	35.6	39.0	42.2	45.2	48.0	50.7	53.2
7°	25.5	29.5	33.0	36.1	39.1	41.8	44.4	46.9	49.3
8°	23.9	27.6	30.8	33.8	36.6	39.1	41.6	43.9	46.1
9°	22.5	26.0	29.1	31.9	34.5	36.9	39.2	41.4	43.5
10°	21.3	24.7	27.6	30.2	32.7	35.0	37.2	39.3	41.2
12°	19.5	22.5	25.2	27.6	29.9	32.0	33.9	35.8	37.6
14°	18.0	20.8	23.3	25.6	27.6	29.6	31.4	33.2	34.8
16°	16.9	19.5	21.8	23.9	25.9	27.7	29.4	31.0	32.6
18°	15.9	18.4	20.6	22.6	24.4	26.1	27.7	29.2	30.7
20°	15.1	17.4	19.5	21.4	23.1	24.7	26.3	27.8	29.2
25°	13.5	15.6	17.4	19.1	20.7	22.1	23.5	24.8	26.1
30°	12.3	14.2	15.9	17.5	18.9	20.2	21.5	22.6	23.8

\*See text under "Speed and Unbalanced Elevation for Curvature."

In an effort to bring order to the "as many opinions as there are individuals" Stevens and Ray continue their trigonometric approach in the formulas developed above. The results of which for a curve of given radius and superelevation is a velocity greater than equilibrium although limited in increased velocity by a margin ascertained to be such that will avoid unacceptable discomfort to a passenger riding on a train rounding the curve. Steven's and Ray's report does not expound on the methodology employed during their "study of speeds through turnouts and around curves" that resulted in the establishment of 3 inches of unbalanced superelevation as being the limiting margin greater than equilibrium.

Included in Steven's and Ray's 1914 report is the diagram titled "Speeds of Trains Through Level Turnouts" the vertical axis of which is labeled "Degree of Lead Curve." The lead curve, located between the heel of the switch and the toe of the frog, is a simple curve for the turnouts represented by the diagram, thus the diagram characteristic curves may be considered applicable to a simple curve of any length maintained at zero cross level or without super elevation on standard 56.5 inch gage track. The diagram illustrates comparisons between three fundamental diagram characteristic curves of velocity vs. curve radius, with curve radius in this case being specified as degree of curve 100.0 foot chord basis instead.

## SPEEDS OF TRAINS THROUGH LEVEL TURNOUTS

HEIGHT OF CENTER OF GRAVITY = 84"

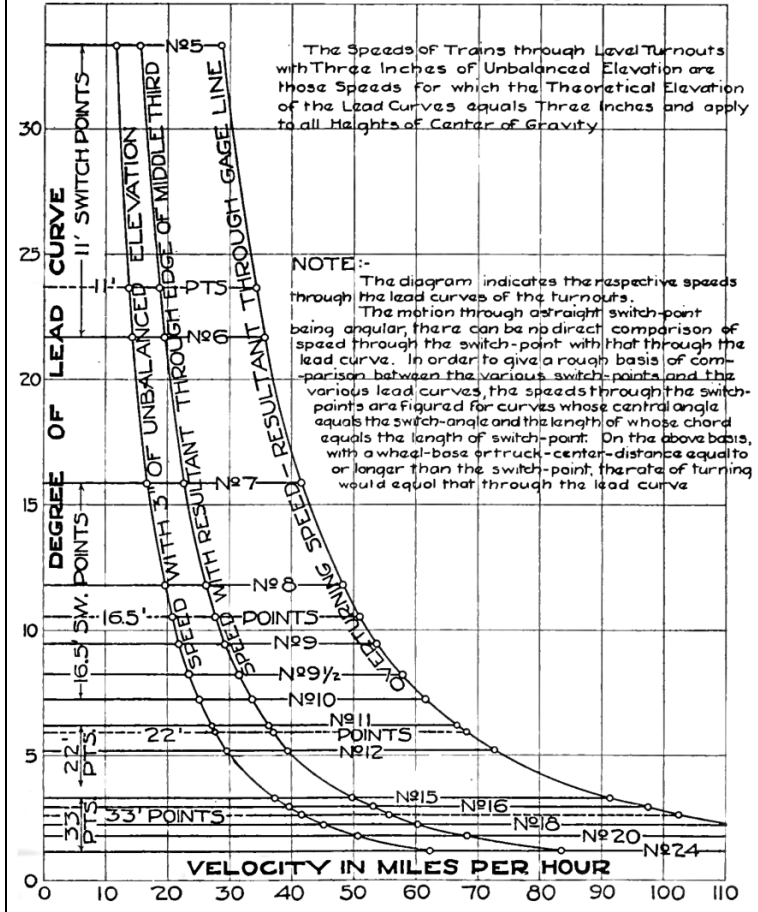

DESCRIPTION OF POINTS OF INTERSECTION OF  
RESULTANT FORCE WITH PLANE OF TRACK  
ON STANDARD 56.5 INCH GAGE TRACK  
Drawing DRTRK13 Figure K

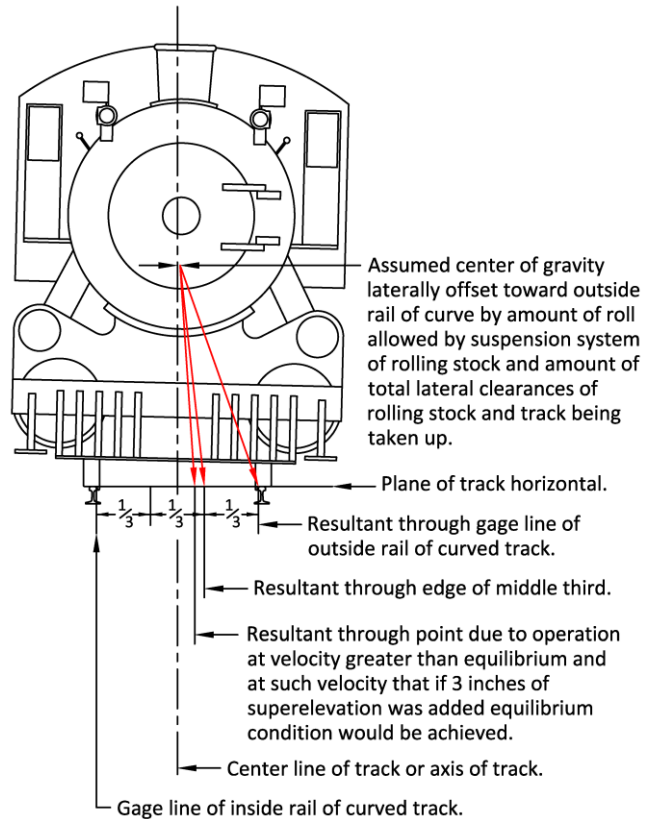

The diagram characteristic curve on the left is that for combinations of degree of curve and velocity where the resultant of forces intersects the plane of track through a point away from the center line of track and toward the outside rail due to operation at non-equilibrium conditions such that if 3 inches of superelevation was added equilibrium condition would be archived instead for the same combinations of degree of curve and velocity. Thus this characteristic curve is labeled "Speed with 3 Inches of Unbalanced Elevation." The dimension of 3 inches proposed by Stevens and Ray and related to their explanation pertaining to passenger comfort and fixed level of disturbance. In the proceedings of the 30<sup>th</sup> annual convention of the A.R.E.A. held in 1929 the foregoing is referred to by a number of railway company engineering officials as comfortable velocity or comfortable speed. In the proceedings of the 37<sup>th</sup> annual convention of the A.R.E.A. held in 1936 it is reported that operation under the foregoing described 3 inch unbalanced conditions will produce a resultant of forces that intersects the plane of track through a point "practically six inches beyond the center line of track, where center of gravity is 84 inches above rail, with an allowance of 1 and 1/2 inches for horizontal play in equipment."

The diagram characteristic curve in the middle is that for combinations of degree of curve and velocity where the resultant of forces intersects the plane of track at the point known as the edge of the middle third or approximately 9.4 inches from the center line of track. In the proceedings of the 30<sup>th</sup> annual convention of the A.R.E.A. held in 1929 the foregoing is referred to by a number of railway company engineering officials as safe velocity or safe speed.

The diagram characteristic curve on the right is that of overturning conditions and from an engineering department perspective may be useful in understanding the extreme limits of the circumstances under study. Although from an operating department perspective overturning condition data is of minimal value given that the engineering department will most likely specify maximum curve velocities such that will avoid overturning conditions by a sufficient margin of safety and most likely not more than that depicted by the diagram characteristic curve labeled "Speed with Resultant Through Edge of Middle Third."

There is no diagram characteristic curve for equilibrium conditions, nor can there be, as any movement or velocity of rolling stock along a level curve results in an under balanced non-equilibrium condition.



## Superelevation Information Provided by the C.&A.R.R. Presented at the A.R.E.A. 30<sup>th</sup> Annual Convention 1929.

Of the many responses received pertaining to the request for superelevation information, that received from the Chicago and Alton Railroad is of particular interest in that Chief Engineer R. A. Cook suggests that the distance between the vertical center lines of the rails be employed for variable  $G$  in the equilibrium elevation formula instead of the distance between the gage lines. This resulting in the formula constant of 0.000689 instead of 0.00066, and appears to coincide more closely with the constant 0.0007 described as being employed by the P.R.R.

### Chicago & Alton—R. A. Cook, Chief Engineer

With respect to the superelevation of the outer rail on curves, I am forwarding you herewith a blue print of our Plan No. 11035 giving the superelevations for various curves and various speeds. This, however, is the same thing as the table appearing on page 184 of the 1921 Manual. I have one criticism to make of this table, which is that it gives the difference in elevation of the two rails at the gage lines. I think, to be strictly correct, it should give the superelevation between the two points, one on each rail of the track, which are most likely to be used by a section foreman in determining the superelevation with a track level. I am under the impression that this is more likely to be the distance between the vertical center lines of the two rails than the distance between the two gage lines of the two rails. The Manual states that the superelevation equals  $.00066 DS^2$ . This formula, I understand, involves using the gage of track. If the distance between the vertical center lines of the two rails is used, however, I understand this formula will be  $E$  equals  $.000689 DS^2$ .

Regarding the speed for which curves are elevated, on ordinary degrees of curvature, which is 4 degrees or less, where passenger trains make high rates of speed, a speed of 50 miles per hour is used. For higher degrees of curvature or where some local condition limits the speed of trains a less speed is used according to circumstances.

W. W. Hay in the 1922 2<sup>nd</sup> edition of his book Railroad Engineering, in formulas and drawings that pertain to superelevation, uses the distance between the bearing points of the wheels on the rails instead of the gage of track. Hay suggesting in a simple illustration of superelevation that this distance be taken as 4.9 feet and in a more complex illustration of superelevation the distance be taken as 60 inches. The dimension of 60 inches may have been selected to simplify the illustration of this dimension being divided into inside third, middle third and outside third portions.

## Superelevation, A.R.E.A. Manual of 1929.

### <sup>4</sup>MAINTENANCE OF SURFACE

#### (a) Elevation of Curves

The approximate formula:

$$E = .00066 DS^2,$$

in which

$E$  = Elevation in inches of the outer rail at the gage line,

$D$  = Degree of Curve, and

$S$  = Speed in miles per hour.

will give essentially correct theoretical elevations for the outer rail of curves, in which the resultant of forces passes practically through the center line of track.

This formula will give results which are expressed in the following table:

ELEVATION OF OUTER RAIL IN INCHES

Degree of Curve.	Velocity in Miles per Hour												Degree of Curve.	
	10	15	20	25	30	35	40	45	50	55	60	65		70
1	0	1/8	1/4	3/8	1/2	5/8	3/4	7/8	1	1 1/8	1 1/4	1 1/2	1 3/4	1
2	0	1/4	1/2	3/4	1	1 1/4	1 1/2	1 3/4	2	2 1/4	2 1/2	2 3/4	3	2
3	0	1/2	3/4	1 1/4	1 1/2	2	2 1/4	2 3/4	3	3 1/4	3 1/2	3 3/4	4	3
4	0	3/4	1 1/4	2	2 1/4	3	3 1/4	4	4 1/4	4 1/2	4 3/4	5	5 1/4	4
5	0	1	1 1/2	2 1/4	2 3/4	3 1/2	4	4 1/2	5	5 1/4	5 1/2	5 3/4	6	5
6	0	1 1/4	2 1/4	3 1/4	4	5	5 1/4	6	6 1/4	6 1/2	6 3/4	7	7 1/4	6
7	0	1 1/2	2 3/4	4	5	6 1/4	7	7 1/4	8	8 1/4	8 1/2	8 3/4	9	7
8	0	1 3/4	3	4 1/4	5 1/4	6 3/4	7 1/2	8 1/4	9	9 1/4	9 1/2	9 3/4	10	8
9	0	2	3 1/4	4 3/4	6	7 1/4	8 1/4	9 1/4	10	10 1/4	10 1/2	10 3/4	11	9
10	0	2 1/4	3 3/4	5 1/4	6 3/4	8 1/4	9 1/4	10 1/4	11	11 1/4	11 1/2	11 3/4	12	10
11	0	2 1/2	4	5 1/2	7 1/4	8 3/4	10 1/4	11 1/4	12	12 1/4	12 1/2	12 3/4	13	11
12	0	2 3/4	4 1/4	5 3/4	7 3/4	9 1/4	10 3/4	12 1/4	13	13 1/4	13 1/2	13 3/4	14	12
13	0	3	4 1/2	5 3/4	7 3/4	9 1/4	10 3/4	12 1/4	13	13 1/4	13 1/2	13 3/4	14	13
14	0	3 1/4	4 3/4	6	7 3/4	9 1/4	10 3/4	12 1/4	13	13 1/4	13 1/2	13 3/4	14	14
15	0	3 1/2	5	6 1/4	7 3/4	9 1/4	10 3/4	12 1/4	13	13 1/4	13 1/2	13 3/4	14	15
16	0	3 3/4	5 1/4	6 3/4	8 1/4	9 1/4	10 3/4	12 1/4	13	13 1/4	13 1/2	13 3/4	14	16
17	0	4	5 1/4	6 3/4	8 1/4	9 1/4	10 3/4	12 1/4	13	13 1/4	13 1/2	13 3/4	14	17
18	0	4 1/4	5 3/4	7	8 1/4	9 1/4	10 3/4	12 1/4	13	13 1/4	13 1/2	13 3/4	14	18
19	0	4 1/2	5 3/4	7 1/4	8 3/4	9 1/4	10 3/4	12 1/4	13	13 1/4	13 1/2	13 3/4	14	19
20	0	4 3/4	6	7 1/4	8 3/4	9 1/4	10 3/4	12 1/4	13	13 1/4	13 1/2	13 3/4	14	20

NOTE.—There will be found on page 899, Vol. 30, Proceedings, 1929, a comparison in tabular form of curve elevations for equilibrium speed with "comfortable," "safe," and theoretical "overturning" speeds.

Since the elevation required is a function of the train speed this speed is the first element to be determined.

In general, in determining speed for which a curve shall be elevated, it is necessary to consider traffic which includes moderately slow freight and relatively fast passenger trains. To secure economy in the operation of freight trains and comfort for passenger traffic, the selection of a speed in varying degrees less than the speed of the passenger trains over that particular curve is recommended.

Where easement curves are used the elevation should be attained and run out as prescribed under "Maintenance of Line, (b) Curves; Use of Easement Curves."

<sup>4</sup>Adopted, Vol. 3, 1902, pp. 56-59, 78-87; Vol. 5, 1904, pp. 528-533, 535, 562, 563; Vol. 6, 1905, pp. 754-757, 759-761; Vol. 11, Part 2, 1910, pp. 935, 944; Vol. 12, Part 1, 1911, pp. 402, 465; Vol. 16, 1915, pp. 732, 1145; Vol. 30, 1929, pp. 895, 1428.

#### <sup>6</sup>SPEEDS OF TRAINS THROUGH CURVES AND TURNOUTS

Diagrams of speeds of trains through curves and level turnouts are shown in following pages.

<sup>6</sup>Adopted, Vol. 15, 1914, pp. 594, 1063.

Superelevation, A.R.E.A. Manual of 1929, continued.

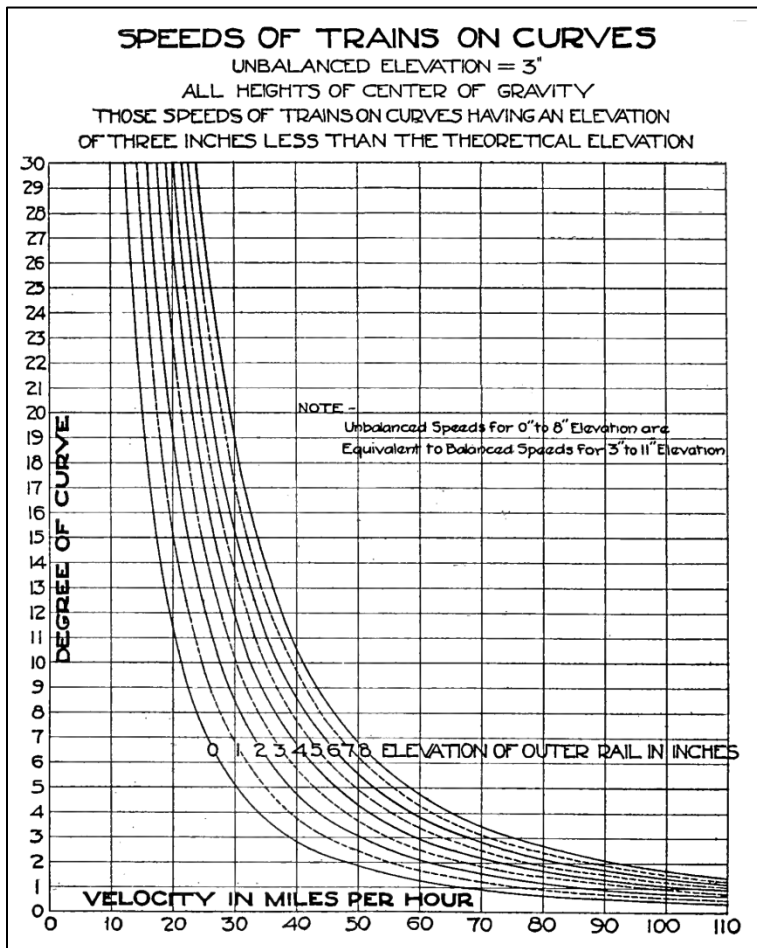

In the 1929 Manual under the heading Maintenance of Surface, (a) Elevation of Curves, the approximate formula for equilibrium elevation remains essentially unchanged from that illustrated in the 1905 A.R.E.M.A. proceedings except that the variable V for velocity in miles per hour has been changed to S for speed in miles per hour. Steven's and Ray's trigonometric based method for ascertaining equilibrium elevation, presented in 1914, having not been adopted in subsequent Manuals most likely due to the added complication resulting from the use of trigonometric functions or tables.

Under the heading Speeds of Trains Through Curves and Turnouts, only three of Steven's and Ray's original five diagrams are presented, "Speeds of Trains on Curves, Resultant Through Edge of Middle Third," "Speeds of Trains on Curves, Unbalanced Elevation = 3 Inches" and "Speeds of Trains Through Level Turnouts, Result of Forces Through Points at Varying Distances from Center Line of Track." The last of the foregoing diagrams not to be confused with the diagram presented on a previous page of this article.

Steven's and Ray's two other original diagrams titled "Speeds of Trains on Curves, Overturning Speeds - Resultant Through Gage Line" and "Speeds of Trains Through Level Turnouts," although adopted in 1914 and included in the 1921 Manual, were subsequently withdrawn before publication of the 1929 Manual.

Superelevation, A.R.E.A. 37<sup>th</sup> Annual Convention 1936.

MAINTENANCE OF SURFACE	
<p>(a) Elevation of Curves                  The approximate formula:  <math display="block">e = \frac{Gv^2}{32.16 R}</math>                 in which  <math>e</math> = Elevation in feet,  <math>G</math> = Gage of track in feet,  <math>v</math> = Velocity in feet per second,  <math>R</math> = Radius of curve in feet,                  will give essentially correct theoretical elevation for the outer rail of curves.                  From the above may be derived the simpler formula,  <math display="block">E = .00066 DS^2</math></p>	<p>in which  <math>E</math> = Elevation in inches of the outer rail at the gage line,  <math>D</math> = Degree of curve,  <math>S</math> = Speed in miles per hour,                  and from this the approximate formula:  <math display="block">E = .00066 DS^2 - 3,</math>                 will give 3-inch unbalanced speed elevations for the outer rail of curves, in which the resultant of forces passes practically six inches beyond the center line of track, where center of gravity is 84 in. above rail, with an allowance of 1½-in. for horizontal play in equipment.                  The following table gives the speeds in miles per hour in multiples of 5 (which is the general practice for use on speed-limit signs) for equilibrium and three-inch unbalanced elevations.</p>

In the 1936 proceedings the approximate formula for equilibrium elevation remains unchanged from that illustrated in the 1929 Manual although is followed by a new formula the result of which "will give 3-inch unbalanced speed elevations..." The new formula coinciding with Steven's and Ray's original suggestion for comfortable under balanced non-equilibrium conditions and further reinforced in the Speed Table for Curves as the "Maximum Speed in Miles per Hour Recommended as Good Practice ...." and "M = Maximum Speed = Speed at 3 Inch Unbalanced Elevation."

Not included with the presentation of the new formula is an explanation of the fact that a point will be reached in the combinations of increasing degree of curve and decreasing speed in miles per hour where the result E will be less than zero. In such case the track is maintained at zero cross level.

### SPEED TABLE FOR CURVES

MAXIMUM SPEED IN MILES PER HOUR RECOMMENDED AS GOOD PRACTICE (NOT LIMITS OF SAFETY) WHERE CENTER OF GRAVITY IS 84 INCHES ABOVE THE TOP OF RAIL

E = Speed at Equilibrium Elevation  
M = Maximum Speed = Speed at 3" Unbalanced Elevation

DEGREE OF CURVE	ELEVATION OF OUTER RAIL	1"	1 1/4"	1 1/2"	1 3/4"	2"	2 1/4"	2 1/2"	2 3/4"	3"	3 1/4"	3 1/2"	3 3/4"	4"	4 1/4"	4 1/2"	4 3/4"	5"	5 1/4"	5 1/2"	5 3/4"	6"	6 1/4"	6 1/2"	6 3/4"	7"	ELEVATION OF OUTER RAIL	DEGREE OF CURVE	
0°30'	100	40	50	55	60	65	70	75	80	85	90	95	100	105	110												E	0°30'	
1°00'	75	25	35	40	45	50	55	60	65	70	75	80	85	90	95	100	105	110	115	120								E	1°00'
1°30'	50	10	20	25	30	35	40	45	50	55	60	65	70	75	80	85	90	95	100	105	110							E	1°30'
2°00'	25		10	15	20	25	30	35	40	45	50	55	60	65	70	75	80	85	90	95	100							E	2°00'
2°30'	10			5	10	15	20	25	30	35	40	45	50	55	60	65	70	75	80	85	90							E	2°30'
3°00'	5				5	10	15	20	25	30	35	40	45	50	55	60	65	70	75	80	85							E	3°00'
3°30'						5	10	15	20	25	30	35	40	45	50	55	60	65	70	75	80							E	3°30'
4°00'							5	10	15	20	25	30	35	40	45	50	55	60	65	70	75							E	4°00'
4°30'								5	10	15	20	25	30	35	40	45	50	55	60	65	70							E	4°30'
5°00'									5	10	15	20	25	30	35	40	45	50	55	60	65							E	5°00'
5°30'										5	10	15	20	25	30	35	40	45	50	55	60							E	5°30'
6°00'											5	10	15	20	25	30	35	40	45	50	55							E	6°00'
7°00'												5	10	15	20	25	30	35	40	45	50							E	7°00'
8°00'													5	10	15	20	25	30	35	40	45							E	8°00'
9°00'														5	10	15	20	25	30	35	40							E	9°00'
10°00'															5	10	15	20	25	30	35							E	10°00'
11°00'																5	10	15	20	25	30							E	11°00'
12°00'																	5	10	15	20	25							E	12°00'

*Since the elevation required is a function of the train speed, this speed is the first element to be determined. In general, in determining speed for which a curve shall be elevated, it is necessary to consider the different speeds at which various classes of trains operate. Where conditions do not warrant greater speeds, equilibrium speeds should be used. It is recommended that for good riding conditions on passenger trains and minimum wear on rail and equipment, the speeds be kept within the limits shown in this table. The limits as shown will also serve for use on any lower height center of gravity, as the speeds for 3" unbalanced elevation for 84" height center of gravity are approximately the same as for 2 1/4" unbalanced elevations for 54" center of gravity. For traffic of one speed equilibrium elevation is the most economical. Where both fast and slow trains are operated on the same track it is advisable to increase the speed limit of fast trains above those shown for equilibrium speed. For a preponderance of slow traffic where schedules make it necessary and conditions of track permit, speeds up to the maximum shown may be used. It will be noted that for the sharper curves there is little difference in the number of miles per hour that may be run at each of the various superelevations.*

In the Speed Table for Curves the minimum superelevation column is 1/4 inch, thus the table is not specifically applicable to level curves. If a column for 0 inches superelevation had been included, it would have provided for level curves although only maximum speeds "M" at 3 inches unbalanced elevation could be listed as any movement or velocity of rolling stock along a level curve results in an under balanced non-equilibrium condition.

Included below the speed data of the table are instructions relating to elements or circumstances that must be considered before applying superelevation to a given curve.

From the 1936 A.R.E.A. formula  $E = 0.00066 * D * V^2 - 3$  may be derived Formula 12.

$$V_{max} = \text{Sqrt} \left( \frac{E + 3}{0.00066 / D} \right) \dots \text{Formula 12.}$$

where:

- V<sub>max</sub> = Maximum speed in miles per hour, 3 inches unbalanced elevation basis.
- E = Actual superelevation in inches.
- D = Degree of curve 100.0 foot chord basis.

Steven's and Ray's original suggestion of 3 inches of unbalanced elevation providing comfortable under balanced non-equilibrium conditions, although considered by the P.R.R to be conservative, has withstood the test of time given that as of 2011 the United States Federal Railroad Administration formula for ascertaining maximum allowable operating speed on standard 56.5 inch gage curved track is presented as Formula 13 and is applicable to rolling stock not exhibiting specified increased suspension system roll stability characteristics.

$$V_{max} = \text{Sqrt} \left( \frac{E_a + 3}{0.0007 / D} \right) \dots \text{Formula 13.}$$

where:

- V<sub>max</sub> = Maximum speed in miles per hour, 3 inches unbalanced elevation basis.
- E<sub>a</sub> = Actual superelevation in inches.
- D = Degree of curve 100.0 foot chord basis.

**Equilibrium Elevation, 1:8 Scale Miniature Practice vs. Full Size Practice.**

From Steven’s and Ray’s work is derived Formula 14 below.

$$x = \tan^{-1} ( v^2 / ( g * R ) ) \dots\dots \text{Formula 14.}$$

where:

x = Force triangle angle of resultant from vertical, thus also equilibrium angle of cant of track from horizontal, in decimal degrees.

v = Velocity in feet per second.

g = Acceleration due to gravity taken as 32.16 feet per second per second.

R = Radius of curve in feet.

From the above then for typical rolling stock having a center of gravity located midway between its overall width, and rounding a curve at a velocity of 8 miles per hour (approximately 11.73 feet per second) and the curve having a radius of 480 feet and angle of cant of track of 0.511 degrees, the rolling stock will round the curve under equilibrium condition regardless of whether the gage of track is 7.5 inches or 56.5 inches.

From Steven’s and Ray’s work, and Hay’s work, and Formulas 10 and 10K of this article is derived Formula 15 below.

$$Ee = B * \sin ( \tan^{-1} ( 0.06689 * V^2 / R ) ) \dots\dots \text{Formula 15.}$$

where:

Ee = Equilibrium elevation of outside rail of curve in inches.

B = Distance between the bearing points of the wheels on the rails in inches.

$$0.06689 \approx ( 5280 / 3600 )^2 * ( 1 / 32.16 )$$

V = Velocity in miles per hour.

R = Radius of curve in feet.

Table No. 1

**Comparison of Curve Equilibrium Elevations, 1:8 Scale Miniature Practice vs. Full Size Practice.**

Miniature velocity = Full size velocity divided by 8.

Miniature curve radius = Full size curve radius divided by 8.

Miniature bearing distance B = Full size bearing distance B divided by 7.35.

Miniature wheel diameter of 4.5 inches = Full size wheel diameter of 36 inches divided by 8.

Equilibrium Elevation Ee From Formula 15.

7.5 Inch Gage Track B = 8.0 Inches Curve Radius 60 Feet Wheel Diameter = 4.5 Inches			56.5 Inch Gage Track B = 58.8 Inches Curve Radius 480 Feet Wheel Diameter = 36 Inches		
Actual MPH	(Ee) Equilibrium Elevation Inches	Wheel Set R.P.M	Wheel Set R.P.M.	(Ee) Equilibrium Elevation Inches	Actual MPH
1	0.009	74.7	74.7	0.524	8
2	0.036	149.4	149.4	2.096	16
2.39	0.051	178.8	178.8	3.000	19.15
3	0.080	224.1	224.1	4.705	24
4	0.143	298.8	298.8	8.307	32
5	0.223	373.5	373.5	12.796	40
6	0.321	448.2	448.2	17.975	48

Results from Table No. 1 reveal the relationship between equilibrium elevation for 1:8 scale miniature practice and full size practice is approximately 1:58 and is significantly greater than the 1:8 scale dimensional relationship that is usually considered when constructing 1:8 scale miniature equipment. Taking full size practice superelevation dimensional data and dividing by eight and then applying that in miniature practice may result in track work that appears to be in scale to that of full size practice, although will result in an overbalanced superelevation condition in miniature practice.

**Maximum Comfortable Curve Velocity, 1:8 Scale Miniature Practice, Deerfield and Roundabout Railway.**

Experience on the nominal 7.5 inch gage of track Deerfield and Roundabout Railway has revealed that when rolling stock exhibiting typical 1:8 scale miniature practice roll stability characteristics is operated at a velocity of 2.39 miles per hour on a 60 foot radius curve maintained at zero cross level, operating personnel or passengers seated on rolling stock will generally not experience a sensation of discomfort resulting from the perceived effects of centrifugal force. From Formula 15 and the foregoing experience may be developed comfortable superelevation and velocity formulas that are based on an unbalanced elevation or cant deficiency of 0.051 inches.

$$E_c = E_a = ( B * \sin ( \tan^{-1} ( 0.06689 * V^2 / R ) ) ) - C_d \dots \text{Formula 16.}$$

where:

$E_c$  = Comfortable unbalanced superelevation in inches, 0.051 inches cant deficiency basis.

$E_a$  = Actual super elevation in inches.

$B$  = Distance between the bearing points of the wheels on the rails taken as 8 inches.

$$0.06689 \approx ( 5280 / 3600 )^2 * ( 1 / 32.16 )$$

$V$  = Velocity in miles per hour.

$R$  = Radius of curve in feet.

$C_d$  = Cant deficiency taken as 0.051 inches.

Note: If the result of Formula 16 is less than zero, the track is maintained at zero cross level.

$$V_{max} = \text{Sqrt} ( \tan ( \sin^{-1} ( ( E_a + C_d ) / B ) ) / 0.06689 * R ) \dots \text{Formula 17.}$$

where:

$V_{max}$  = Maximum comfortable velocity in miles per hour, 0.051 inches cant deficiency basis.

$E_a$  = Actual super elevation in inches.

$C_d$  = Cant deficiency taken as 0.051 inches.

$B$  = Distance between the bearing points of the wheels on the rails taken as 8 inches.

$$0.06689 \approx ( 5280 / 3600 )^2 * ( 1 / 32.16 )$$

$R$  = Radius of curve in feet.

**Practical Application of Superelevation, 1:8 Scale Miniature Practice, Deerfield and Roundabout Railway.**

In full size practice superelevation may be practically applied and maintained in increments of one quarter inch or less up to a typical maximum of 8 inches. In 1:8 scale miniature practice a similar multitude of increments of superelevation is generally not practical. The Deerfield and Roundabout Railway has adopted the practice of maintaining tangent track, turnouts and crossings at zero cross level and curves at a superelevation of 0.188 inches.

Table No. 2  
**Deerfield and Roundabout Railway**  
**Maximum Curve Velocity, 0.051 Inches Cant Deficiency Basis.**  
 From Formula 17.

Degree of Curve in Decimal Degrees 12.5 Foot Chord Basis	Curve Radius in Feet	Zero Cross Level Maximum Curve Velocity in Actual MPH	0.188 Inch Super Elevation Maximum Curve Velocity in Actual MPH
18.0 to less than 14.4	40 to less than 50	1.9	4.2
14.4 to less than 12.0	50 to less than 60	2.2	4.7
12.0 to less than 10.2	60 to less than 70	2.4	5.2
10.2 to less than 9.0	70 to less than 80	2.6	5.6
9.0 to less than 8.0	80 to less than 90	2.7	6.0
8.0 to less than 7.2	90 to less than 100	2.9	6.3
7.2 and less than 7.2	100 and greater than 100	3.1	6.7

Note: Provisions of other Deerfield and Roundabout Railway documents shall supersede Fundamentals of Railway Curve Superelevation Table No. 2 maximum velocities inconsistent therewith.

## **Transition Between Zero Cross Level and Superelevation.**

When superelevation is applied to a curve consideration must be given to the procedure that will be used to introduce the change from zero cross level condition of the tangent track preceding the curve to the full superelevation of the curve and then back to zero cross level condition of the tangent track following the curve. The previously described is referred to as run off, run out or run in, regardless of whether the change in rail elevation is considered to be increasing or decreasing. In current full size practice superelevation run off is preferably accomplished in conjunction with the use of easement curves, also known as transition curves or spirals, located before and after a circular curve. The fundamental element of an easement curve being its varying radius that gradually introduces a change in alignment from tangent to circular curve or vice versa. This is taken advantage of by applying superelevation to an easement curve at a rate that corresponds to the rate of change of curvature of the easement curve. Rolling stock traversing at constant velocity an easement curve with run off applied will experience a change in the centrifugal force developed as the radius changes and a generally simultaneous counteracting effect produced by the corresponding change in superelevation. It should be noted that when the word curve is used individually it is generally understood to mean a circular curve or simple curve, that being a curve of constant radius.

During the early period of railway construction and operation in the United States, circa 1900, easement curves before and after a circular curve may not necessarily have been used. Superelevation run off would instead be applied to a given length of tangent track before and after a circular curve. The foregoing is not as satisfactory a method of accomplishing run off as compared to the use of an easement curve due to the fact that the maximum acceptable deviation from zero cross level condition on a tangent track run off may limit the superelevation on the circular curve and thus the velocity on the circular curve. In some cases the run off would be divided with a portion of the run off on the tangent and the remaining run off on the circular curve in an effort to increase the superelevation on the circular curve and thus the velocity. W. M. Camp addresses this issue in his book "Notes on Track," the first edition published by the author in 1903, which includes the following: "The value of easement or transition curves is greatest where sustained high speed is practicable. Elevation for simple circular curves can be run in quite satisfactorily for good speed, [The foregoing refers to run in applied to tangents before and after a circular curve] and it is only where extraordinary results are desired that the greater expense and care necessary to maintain the easement curve can be justified. The most practical or satisfactory application of the easement curve is then not so much to curves so sharp that in any event speed must be reduced in running around them, but to those curves of comparatively smaller degree where, with the aid of the transition curve, the slackening of speed may be avoided; and while by using the transition curve a slightly higher speed on curves of, say, about 6 or 8 deg., might be had with a feeling of greater comfort or security, perhaps, still its use on curves less than 6 or 8 deg. must no doubt be the more justifiable practice. Not necessarily, then, are transition curves best suited to roads of heaviest curvature. Furthermore, it will usually be found that the surroundings which determine the location of a sharp curve will allow of but little room for easements. In any case the easement should be no longer than to give sufficient distance in which to run out the elevation. Any available room beyond this had better be used in reducing the curvature of the central or circular portion of the curve."

The Deerfield and Roundabout Railway from 1977 to 2007 in an effort to simplify aspects of track design and construction did not generally install easement curves. This scheme might be thought of as following the 1903 "Camp philosophy" described for "roads of heaviest curvature." A typical main line curve on the Deerfield and Roundabout Railway has a radius of 75 feet and is equivalent to a 600 foot radius curve in full size practice having a degree of curvature of 9.6 degrees. In early 2008 the engineering department of the Deerfield and Roundabout Railway concluded that in order to better demonstrate full size practice railway engineering practices typically used after the early decades of the Twentieth Century, new main line curve construction on the Deerfield and Roundabout Railway will include easement curves and, where practical and when time permits, existing curves without easements will be realigned and provided with easement curves.

## **Supplemental Benefit of Superelevation, 1:8 Scale Miniature Practice.**

Typical ballasted railway track that has been surfaced to zero cross level or to an established superelevation may after it has been placed in service deviate from the original surfaced condition due to disturbing forces that act upon the track structure. The direction, magnitude and rate of deviation from the original surfaced condition depending on the stability of the track, ballast and roadbed to resist the disturbing forces.

In 1:8 scale miniature practice passenger's may experience an uncomfortable sensation when rounding a curve when the elevation of the outside rail of the curve is lower than the elevation of the inside rail. This might be attributable to a passenger's expectation of leaning toward the center of the curve and instead the passenger car tilts toward the outside of

the curve. In a case where the outside rail of a curve is gradually lowering in elevation relative to the inside rail, the initial application of superelevation provides a period of time before the elevation of the outside rail falls below the elevation of the inside rail.

### Additional Considerations When Applying Superelevation.

For design and survey purposes the reference for the horizontal alignment of railway track as it relates to tangents, horizontal curves, easement curves, turnouts, crossings, etc., is generally taken to be the center line of track. The reference for the vertical surface of railway track as it relates to longitudinal level condition, gradients or vertical curves is generally taken to be the top of the running rails assuming the rails to be at zero cross level. The application of superelevation by its nature disturbs the zero cross level condition of the track, therefore a scheme must be used that provides continuity of reference for the vertical surface of the track. This is generally accomplished by maintaining the inside rail of a curve at the established reference for vertical surface and elevating the outside rail the required superelevation relative to the inside rail.

In typical 1:8 scale miniature practice track construction the track will be brought to proper horizontal alignment, vertical surface and to a zero cross level condition relative to offset grade stakes that are set at a known distance from the center line of track and marked to indicate the elevation of top of rail without consideration for superelevation. Superelevation, if used, is then applied as a second step by raising the outside rail of the curve relative to the inside rail by the use of a spirit level to determine when then desired superelevation is achieved. Run off applied to an easement curve or tangent track before and after a circular curve is accomplished in a similar manner using the spirit level.

Installation of turnouts and crossings on curved track requires that special attention be given to the effect that superelevation of one track may have on another. In these circumstances potential superelevation of a given track, and thus maximum velocity, might be limited by the constraints imposed by a turnout or crossing track. Motor vehicle roadway crossings of superelevated railway track or tracks may cause similar disturbances to aspects of the vertical surface of the roadway.

Of consideration more in full size practice than in 1:8 scale miniature practice is the effect that superelevation may have on the tilting of rolling stock with resulting effect on the clearance between rolling stock on adjacent tracks or between track side structures, including tunnel walls, overhead bridge supports, etc., etc.

### Explanation of Curve Radius and Degree of Curve.

Railway curves in full size practice in the United States are generally designated by degree of curvature or degree of curve instead of by radius. This is a natural result of the use of surveying methods and instruments that use deflection angles to locate the survey stations of a curve. In 1:8 scale miniature practice curves are generally designated by radius. This due to the lineal measuring techniques typically used to locate the survey stations of a curve. Due to the different designations of curvature the relationship between curves in full size practice and 1:8 scale miniature practice is not as easily understood as the basic 1:8 scale dimensional relationship.

Drawing DRTRK13 Figure L and Formulas 18 and 19 illustrate the derivation of the designation of a curve by degree of curvature by chord basis. The actual length of a curve may be greater than or less than the standard chord C (red dashed line) and is of no consequence in determining the degree of curvature.

RELATIONSHIP BETWEEN CURVE RADIUS AND  
DEGREE OF CURVE CHORD BASIS  
Drawing DRTRK13 Figure L

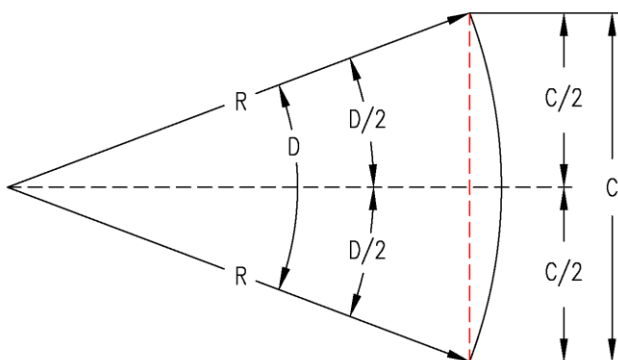

$$D = 2 * \sin^{-1} ( C / 2 / R ) \dots\dots \text{Formula 18}$$

therefore:

$$R = ( C / 2 ) / \sin ( D / 2 ) \dots\dots \text{Formula 19}$$

where:

D = Degree of curvature or degree of curve in decimal degrees based on standard chord length C.

C = Standard chord length in feet. Taken as 100.0 for United States full size practice.

R = Radius of curve in feet.

An alternate method of designating degree of curvature is by arc basis, where a standard distance, similar in purpose to C, is measured along the arc of the curve instead. Typical railway engineering practice in the United States uses chord basis, therefore further references to any degree of curvature shall be understood to mean chord basis and in the case of full size practice it shall be understood to mean a standard chord of 100.0 feet.

Drawing DRTRK13 Figure M illustrates the principle of a surveying method that employs deflection angles to stake out the survey stations on a curve. The variables C and D of Formula 18 also apply to Drawing DRTRK13 Figure M. The red dashed lines illustrate the standard chord length C that determines the distance between survey stations on the curve starting at the point of tangent to curve (T.C.). Angles A1 and A2 are deflection angles to respective intermediate stations on the curve. Angle A3 is the deflection angle to the point of curve to tangent (C.T.) and is generally referred to as the total deflection angle. T.C. being the vertex for each of angles A1, A2 and A3 and all measured from the dashed black line that is tangent to the curve and extends to the right of T.C. and is a prolongation of the solid black line to the left of T.C. If the degree of curvature D is assumed to be 16.0 degrees, then deflection angle A1 is 8.0 degrees, deflection angle A2 is 16.0 degrees and total deflection angle A3 is 24.0 degrees.

**LAYOUT OF HORIZONTAL CURVE BY DEFLECTION ANGLES**  
**Drawing DRTRK13 Figure M**

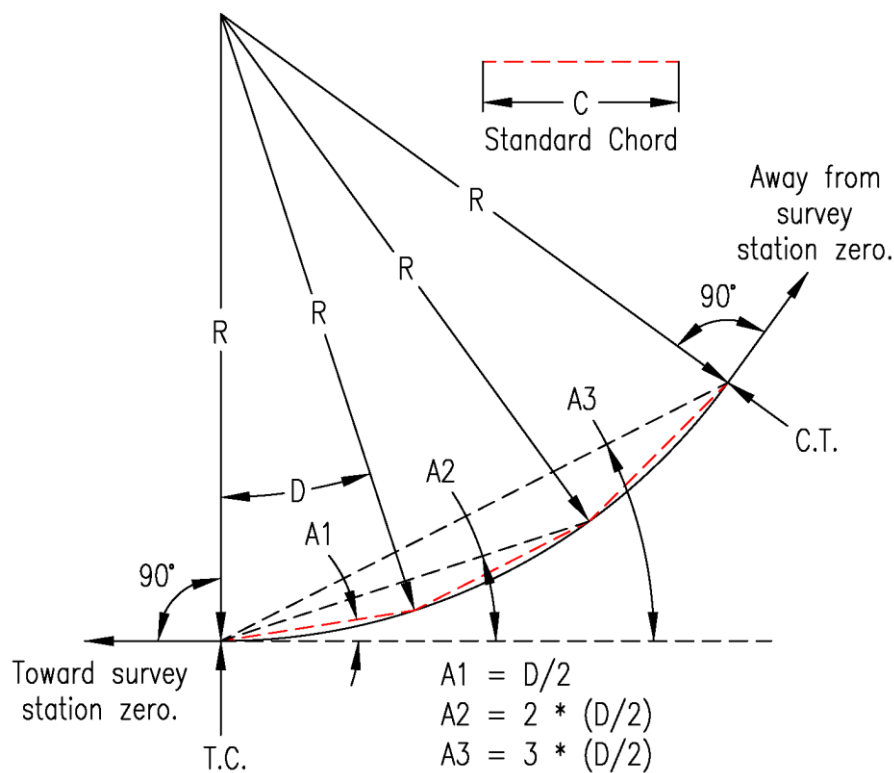

When a curve such as in Drawing DRTRK13 Figure M is referred simply as a 16 degree curve, it is generally understood to mean the degree of curvature. This should not be confused with the angle of a curve from T.C. to C.T. the vertex being the center of the curve. Unlike Drawing DRTRK13 Figure M, in actual practice the circumstances that dictate the required length of a curve from T.C. to C.T. generally does not result in a multiple number of exact standard chord lengths C. In such a case the first chord after T.C. or the last chord before C.T. or both will be sub chords of a length less than the standard chord C. An explanation of sub chords is beyond the scope of this article.

On the following page is presented Table No. 3 that was prepared using Formula 19. For full size practice a standard chord length of 100.0 feet was used for C. For direct comparison purposes between full size practice and 1:8 scale miniature practice a standard chord length of one-eighth that of full size practice was used for C that being 12.5 feet. Although the use of a standard chord length of 12.5 feet provides for direct comparison, the use of a standard chord length of 10.0 feet for C in 1:8 scale miniature practice construction provides for simplification when staking out curves using deflection angles.

Table No. 3  
**Relationships Between Curve Radius and Degree of Curve**

Full Size Practice		1:8 Scale Miniature Practice		
Curve Radius in Feet	Degree of Curve 100.0 Foot Chord Basis	Degree of Curve 12.5 Foot Chord Basis For Comparison	Degree of Curve 10.0 Foot Chord Basis For Construction	Curve Radius in Feet
5729.65	1.0	1.0	0.80	716.21
2864.93	2.0	2.0	1.60	358.12
1910.08	3.0	3.0	2.40	238.76
1432.69	4.0	4.0	3.20	179.09
1146.28	5.0	5.0	4.00	143.28
955.37	6.0	6.0	4.80	119.42
819.02	7.0	7.0	5.6	102.38
716.78	8.0	8.0	6.40	89.60
637.27	9.0	9.0	7.20	79.66
573.69	10.0	10.0	8.00	71.71
521.67	11.0	11.0	8.79	65.21
478.34	12.0	12.0	9.59	59.79
441.68	13.0	13.0	10.39	55.21
410.28	14.0	14.0	11.19	51.28
383.06	15.0	15.0	11.99	47.88
359.26	16.0	16.0	12.78	44.91

**Definitions.**

**CIRCULAR CURVE** - A curve having a radius of constant dimension. Also known as a simple curve. When the word curve is used alone it is generally understood to mean a circular curve.

**EASEMENT CURVE** - A curve having a radius of changing dimension. The rate of change of radius being in one direction and may be determined by a number of accepted formulas. Also known as a transition curve, spiral curve or spiral.

**SUPERELEVATION** - The banking of track by raising or superimposing the outside rail above the inside rail at a curve. The desired speed and curve degree or curve radius determine the amount of superelevation. Also known as elevation or raise when referring to railway track. More recently may also be known as cant. Should not be confused with canted rail.

**BALANCED SUPERELEVATION** - The superelevation applied to a curve of given radius on which rolling stock when operated at a given velocity results in an equal downward force on both rails. Also known as balanced elevation or equilibrium elevation. More recently may also be known as balanced cant.

**EQUILIBRIUM VELOCITY** - The velocity of rolling stock when operated on a curve of given radius and superelevation that results in an equal downward force on both rails. Also known as balanced velocity.

**UNDER BALANCED SUPERELEVATION** - The superelevation applied to a curve on which rolling stock is permitted to operate at greater than equilibrium velocity. Also known as unbalanced superelevation or unbalanced elevation. More recently may also be known as unbalanced cant.

**CANT DEFICIENCY** - The amount that the under balanced superelevation of a curve is less than what would be the balanced superelevation of the curve.

**RUN OFF, SUPERELEVATION** - The gradual and uniform transition from zero cross level track to superelevation or visa versa. Also known as run in or run out. The use of the terms run off, run in or run out may be used interchangeably regardless of whether the direction of movement is considered to be toward or away from a curve.

**CENTRIFUGAL FORCE** - 1. The apparent force that is felt by an object moving in a curved path that acts outwardly away from the center of rotation. 2. An outward force on a body rotating about an axis, assumed equal and opposite to the Centripetal Force and postulated to account for the phenomena seen by an observer in the rotating body. See other reference sources for detailed explanations of Centrifugal Force and Centripetal Force.

Note: Current Deerfield and Roundabout Railway Definitions of Terms Relating to Track Work, Document DRTRK1, shall supersede Fundamentals of Railway Curve Superelevation definitions inconsistent therewith.

## **References.**

1. Proceedings of annual conventions and Manuals of the American Railway Engineering and Maintenance of Way Association or its formerly named organization the American Railway Engineering Association.
2. William W. Hay, Mgt. E., MS, Ph.D., "Railroad Engineering," Second Edition, 1982.
3. Ralph P. Johnson, ME, "The Steam Locomotive," 1942.
4. W. M. Camp, "Notes on Track, Construction and Maintenance," 1903.
5. Code of Federal Regulations, Title 49 – Transportation, Chapter II - Federal Railroad Administration, Department of Transportation, Part 213 - Track Safety Standards, §213.9 Classes of track: operating speed limits, §213.57 Curves; elevation and speed limitations, October 1, 2011
6. C. Frank Allen, S.B., "Railroad, Curves and Earthwork," 1931.
7. John Clayton Tracy, Ph B., C.E., "Surveying Theory and Practice," 1948.
8. J. G. Hook, "1:8 Scale Model Railway Circular Curve and Spiral Calculator Excel Workbook," 2009.
9. Deerfield and Roundabout Railway, Standards for Level Condition of Tangent and Other Track and Elevation of Curved Track, Document DRTRK33, 2009
10. Dictionary of Railway Track Terms, 2003;
11. Dictionary . com;
12. Merriam-Webster online dictionary.